

Owner's Manual

CRAFTSMAN®

**6.0 HP
17 INCH TINE WIDTH
REAR TINE WITH
COUNTER ROTATING TINES
TILLER**

Model No.
917.293310

- **Safety**
- **Assembly**
- **Operation**
- **Maintenance**
- **Español**
- **Repair Parts**

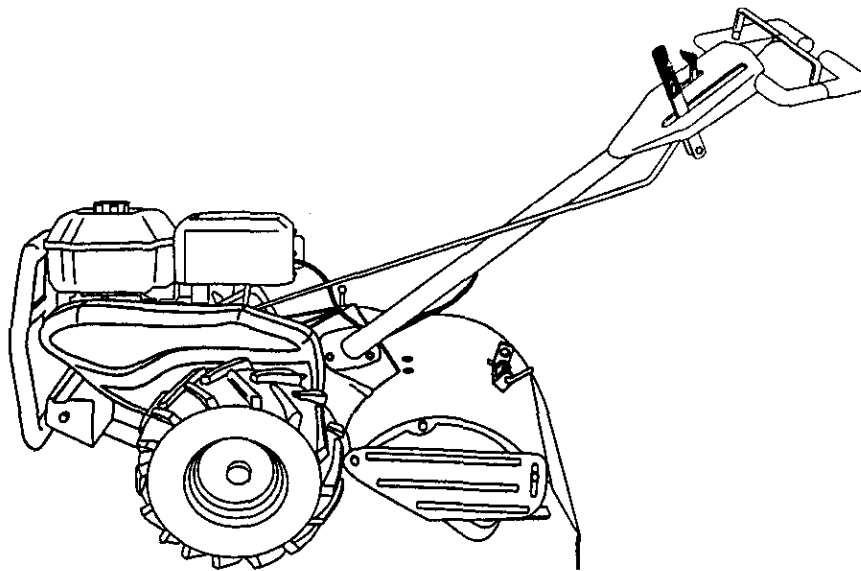

 This product has a low emission engine which operates differently from a two cycle full engine. Before you start the engine, read and understand the Operator's Manual.

CAUTION:

Read and follow all
Safety Rules and Instructions
before operating this equipment

Sears, Roebuck and Co., Hoffman Estates, IL 60179

TABLE OF CONTENTS

Safety Rules.....	2	Service and Adjustments.....	1
Warranty.....	2	Storage.....	1
Product Specifications.....	4	Troubleshooting.....	2
Assembly.....	5	Illustrated Parts List.....	4
Operation.....	8	Parts Ordering.....	Back Cover
Maintenance.....	13		

WARRANTY

LIMITED TWO YEAR WARRANTY ON CRAFTSMAN TILLER

For two (2) years from date of purchase, when this Craftsman Tiller is maintained, lubricated, and tuned up according to the operating and maintenance instructions in the owner's manual, Sears will repair free of charge any defect in material or workmanship.

This Warranty does not cover:

- Expendable items which become worn during normal use, such as tines, spark plugs, air cleaners and belts.
- Repairs necessary because of operator abuse or negligence, including bent crankshafts and the failure to maintain the equipment according to the instructions contained in the owner's manual.
- If this Craftsman Tiller is used for commercial or rental purposes, this Warranty applies for only thirty (30) days from the date of purchase.

Warranty service is available by returning the Craftsman power mower to the nearest Sears service center/department in the United States. This warranty applies only while this product is in use in the United States.

This Warranty gives you specific legal rights, and you may also have other rights which vary from state to state.

SEARS, ROEBUCK AND CO., D/817WA, HOFFMAN ESTATES, IL 60179

SAFETY RULES

TRAINING

- Read the Owner's Manual carefully. Be thoroughly familiar with the controls and the proper use of the equipment. Know how to stop the unit and disengage the controls quickly.
- Never allow children to operate the equipment. Never allow adults to operate the equipment without proper instruction.
- Keep the area of operation clear of all persons, particularly small children, and pets.

PREPARATION

- Thoroughly inspect the area where the equipment is to be used and remove all foreign objects.
- Disengage all clutches and shift into neutral before starting the engine (motor).

- Do not operate the equipment without wearing adequate outer garments. Wear footwear that will improve footing on slippery surfaces.
- Handle fuel with care; it is highly flammable.
- Use an approved fuel container.
- Never add fuel to a running engine or hot engine.
- Fill fuel tank outdoors with extreme care. Never fill fuel tank indoors.
- Replace gasoline cap securely and clean up spilled fuel before restarting.
- Use extension cords and receptacles as specified by the manufacturer for all units with electric drive motors or electric starting motors.
- Never attempt to make any adjustments while the engine (motor) is running (except where specifically recommended by manufacturer).

OPERATION

Do not put hands or feet near or under rotating parts.

Exercise extreme caution when operating on or crossing gravel drives, walks, or roads. Stay alert for hidden hazards or traffic. Do not carry passengers.

After striking a foreign object, stop the engine (motor), remove the wire from the spark plug, thoroughly inspect the tiller for any damage, and repair the damage before restarting and operating the tiller.

Exercise caution to avoid slipping or falling.

If the unit should start to vibrate abnormally, stop the engine (motor) and check immediately for the cause. Vibration is generally a warning of trouble.

Stop the engine (motor) when leaving the operating position.

Take all possible precautions when leaving the machine unattended. Disengage the tines, shift into neutral, and stop the engine.

Before cleaning, repairing, or inspecting, shut off the engine and make certain all moving parts have stopped. Disconnect the spark plug wire, and keep the wire away from the plug to prevent accidental starting. Disconnect the cord on electric motors.

Do not run the engine indoors; exhaust fumes are dangerous.

Never operate the tiller without proper guards, plates, or other safety protective devices in place.

Keep children and pets away.

Do not overload the machine capacity by attempting to till too deep at too fast a rate.

Never operate the machine at high speeds on slippery surfaces. Look behind and use care when backing.

Never allow bystanders near the unit.

Use only attachments and accessories approved by the manufacturer of the tiller.

Never operate the tiller without good visibility or light.

Be careful when tilling in hard ground.

The tines may catch in the ground and propel the tiller forward. If this occurs, let go of the handlebars and do not restrain the machine.

MAINTENANCE AND STORAGE

- Keep machine, attachments, and accessories in safe working condition.
- Check shear pins, engine mounting bolts, and other bolts at frequent intervals for proper tightness to be sure the equipment is in safe working condition.
- Never store the machine with fuel in the fuel tank inside a building where ignition sources are present, such as hot water and space heaters, clothes dryers, and the like. Allow the engine to cool before storing in any enclosure.
- Always refer to the operator's guide instructions for important details if the tiller is to be stored for an extended period.

▲ CAUTION: Always disconnect spark plug wire and place wire where it cannot contact spark plug in order to prevent accidental starting when setting up, transporting, adjusting or making repairs.

WARNING

The engine exhaust from this product contains chemicals known to the State of California to cause cancer, birth defect, or other reproductive harm.

PRODUCT SPECIFICATIONS

HORSEPOWER:	6.0 HP
DISPLACEMENT:	13.53 CU. IN.
GASOLINE CAPACITY:	3 Quarts Unleaded Regular
OIL (API-SF/SG/SH): (CAPACITY: 19 oz.)	SAE 30 (Above 40°F) SAE5W-30/10W-30 (Below 40°F)
SPARK PLUG : (GAP: .030")	Champion RJ19LM OR J19LM

Congratulations on your purchase of a Craftsman Tiller. It has been designed, engineered and manufactured to give you the best possible dependability and performance.

Should you experience any problems you cannot easily remedy, please contact your nearest authorized Sears Service Center/Department. We have competent, well-trained technicians and the proper tools to service or repair this unit.

Please read and retain this manual. The instructions will enable you to assemble and maintain your tiller properly. Always observe the "SAFETY RULES".

Your new tiller has been assembled at the factory with exception of those parts left unassembled for shipping purposes. To ensure safe and proper operation of your tiller all parts and hardware you assemble must be tightened securely. Use the correct tools as necessary to insure proper tightness.

MAINTENANCE AGREEMENT

A Sears Maintenance Agreement is available on this product. Contact your nearest Sears store for details.

CUSTOMER RESPONSIBILITIES

- Read and observe the safety rules.
- Follow a regular schedule in maintaining, caring for and using your tiller.
- Follow the instructions under the "Maintenance" and "Storage" sections, this Owner's Manual.

⚠ WARNING: This unit is equipped with an internal combustion engine and should not be used on or near any unimproved forest-covered, brush-covered or grass covered land unless the engine's exhaust system is equipped with a spark arrester meeting applicable local or state laws (if any). If a spark arrester is used, it should be maintained in effective working order the operator.

In the state of California the above is required by law (Section 4442 of the California Public Resources Code). Other states may have similar laws. Federal laws apply on federal lands. See your Sears Authorized Service Center for spark arrester. Refer to the Repair Parts section of this manual for part number.

ACCESSORIES

These accessories were available when the tiller was purchased. They are also available at most Sears Retail outlets and Service Centers. Most Sears Stores can order repair parts for you when you provide the model number of your tiller.

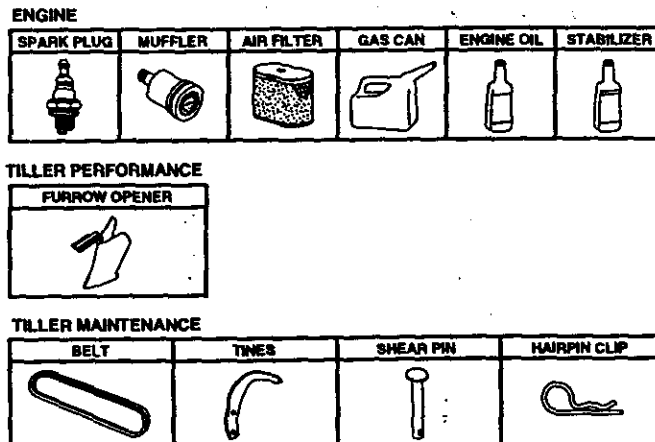

ASSEMBLY

Your new tiller has been assembled at the factory with exception of those parts left unassembled for shipping purposes. To ensure safe and proper operation of your tiller all parts and hardware you assemble must be tightened securely. Use the correct tools as necessary to insure proper tightness.

TOOLS REQUIRED FOR ASSEMBLY

A socket wrench set will make assembly easier. Standard wrench sizes are listed.

- (1) Utility knife
- (1) Wire cutter
- (1) Tire pressure gauge
- (1) Screwdriver
- (1) Pair of pliers
- (1) 9/16" wrench

OPERATOR'S POSITION

When right or left hand is mentioned in this manual, it means when you are in the operating position (standing behind tiller handles).

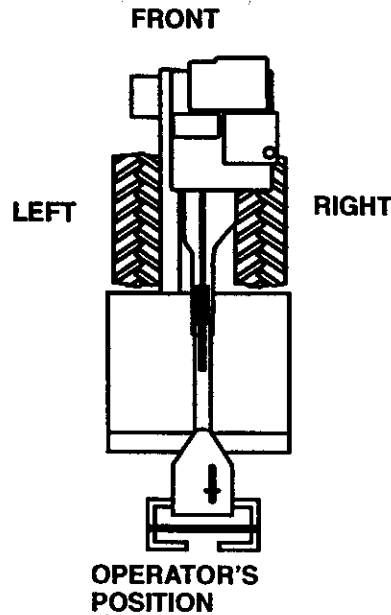

CONTENTS OF HARDWARE PACK



(2) Handle Locks

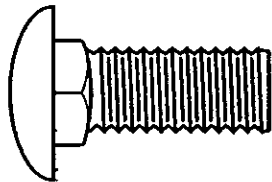

(1) Carriage Bolt
3/8-16 UNC x 1 Gr. 5

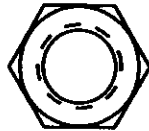

(1) Center Locknut
3/8-16 UNC



(1) Cable Clip



(2) Hairpin Clips

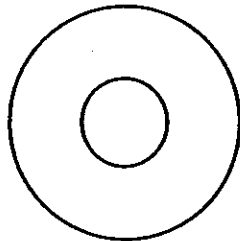

(1) Flat Washer
13/32 x 1 x 11 Ga.

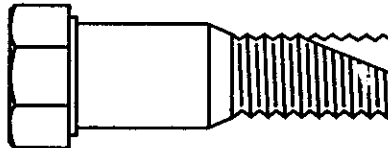

(1) Pivot Bolt
3/8-16 UNC Grade 5

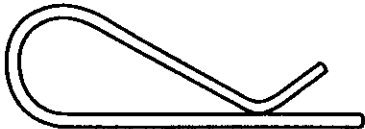

Extra Shear Pins & Clips

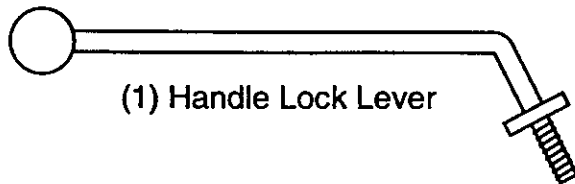

(1) Handle Lock Lever

UNPACKING CARTON

CAUTION: Be careful of exposed staples when handling or disposing of cartoning material.

IMPORTANT: When unpacking and assembling tiller, be careful not to stretch or kink cables.

- While holding handle assembly, cut cable ties securing handle assembly to top frame. Let handle assembly rest on tiller.
- Remove top frame of carton.
- Slowly ease handle assembly up and place on top of carton.
- Cut down right hand front and right hand rear corners of carton, lay side carton wall down.
- Remove packing material from handle assembly.
- Separate shift rod from handle assembly.

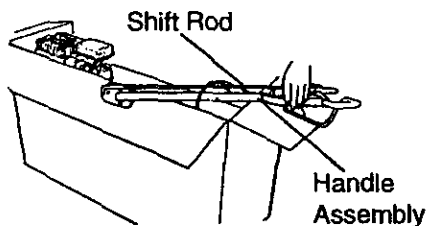

INSTALL HANDLE

- Insert one handle lock (with teeth facing outward) in gearcase notch. (Apply grease on smooth side of handle lock to aid in keeping lock in place until handle assembly is lowered into position.)

VIEWED FROM R.H. SIDE OF TILLER

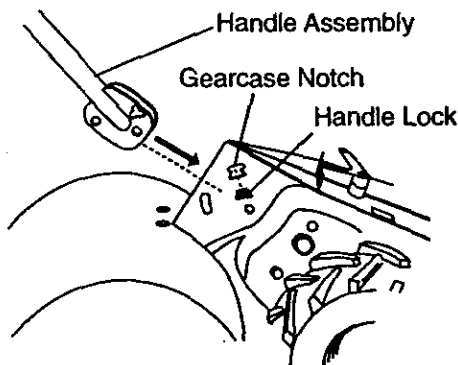

- Grasp handle assembly. Hold in "up" position. Be sure handle lock remains in gearcase notch. Slide handle assembly into position.
- Rotate handle assembly down. Insert rear carriage bolt first, with head of bolt on L.H. side of tiller and loosely assemble locknut.

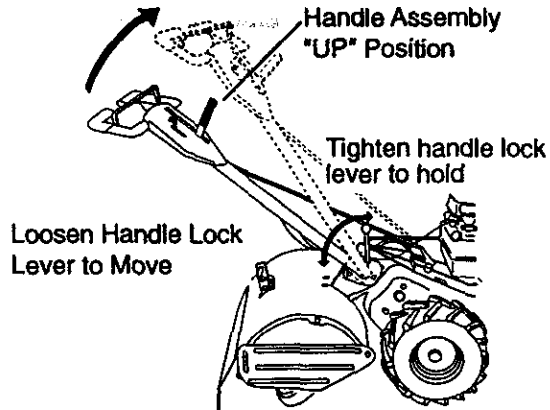

- Insert pivot bolt in front part of plate and tighten.
- Cut down remaining corners of carton and lay panels flat.
- Lower the handle assembly. Tighten nut on carriage bolt so handle moves with some resistance. This will allow for easier adjustment.
- Place flat washer on threaded end of handle lock lever.
- Insert handle lock lever through handle base and gearcase. Screw in handle lock lever just enough to hold lever in place.
- Insert second handle lock (with teeth inward) in the slot of the handle base (just inside of washer).
- Raise handle assembly to highest position and securely tighten handle lock lever by rotating clockwise. Leaving handle assembly in highest position will make it easier to connect shift rod.

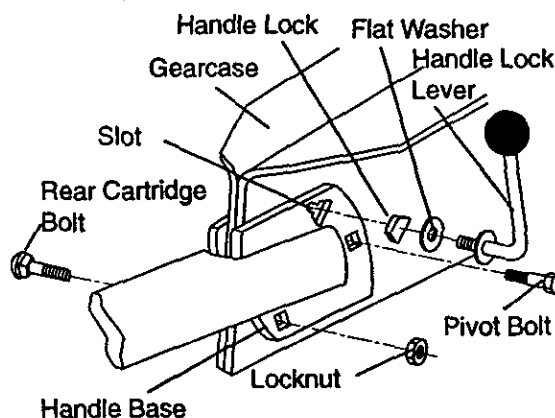

INSERT CABLE CLIP

- Insert plastic cable clip into hole on the back of handle column. Push cables into clip.

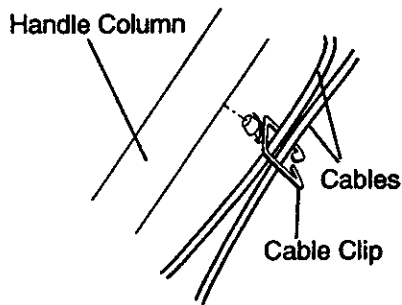

CONNECT SHIFT ROD

- Insert end of shift rod farthest from bend into hole of shift lever indicator.
- Insert hairpin clip through hole of shift rod to secure.
- Insert other end of shift rod into hole in shift lever.
- Insert second hairpin clip through hole of shift rod with bend of clip on right side.

REMOVE TILLER FROM CRATE

- Adjust handle assembly to lowest position. Be sure lock lever is tightened securely.
- Make sure shift lever indicator is in "N" (neutral) position.
- Tilt tiller forward by lifting handle. Separate cardboard cover from leveling shield.
- Rotate tiller handle to the right and pull tiller out of carton.

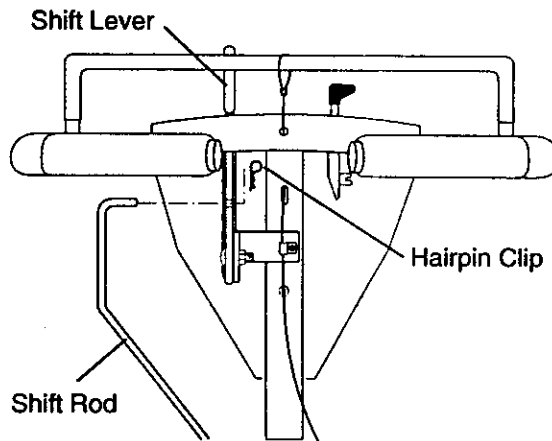
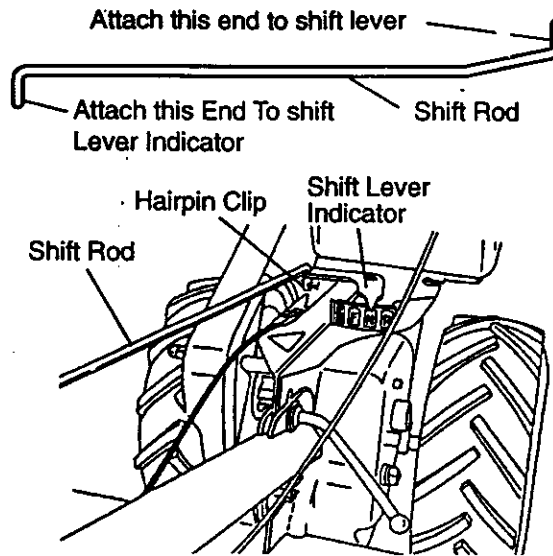

CHECK TIRE PRESSURE

The tires on your unit were overinflated at the factory for shipping purposes. Correct and equal tire pressure is important for best tilling performance.

- Reduce tire pressure to 20 PSI.

HANDLE HEIGHT

- Handle height may be adjusted to better suit operator. (See "TO ADJUST HANDLE HEIGHT" in the Service and Adjustments section of this manual).

OPERATION

These symbols may appear on your Tiller or in literature supplied with the product. Learn and understand their meaning.

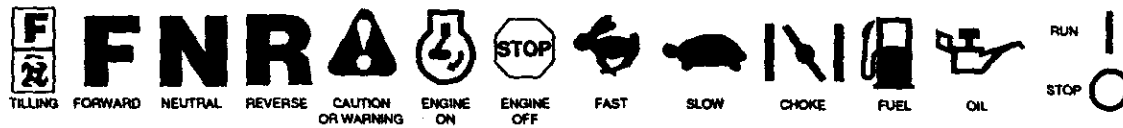

KNOW YOUR TILLER

READ THIS OWNER'S MANUAL AND SAFETY RULES BEFORE OPERATING YOUR TILLER.

Compare the illustrations with your tiller to familiarize yourself with the location of various controls and adjustments. Save this manual for future reference.

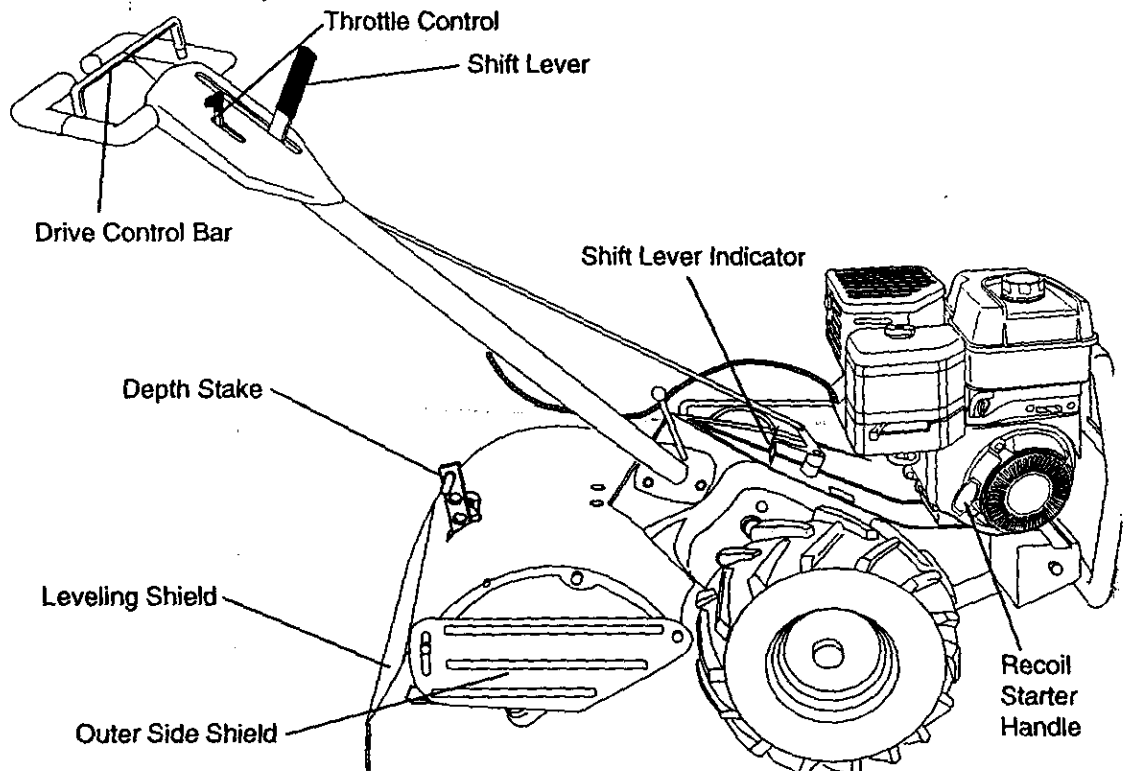

MEETS ANSI SAFETY REQUIREMENTS

Our tillers conform to the safety standards of the American National Standards Institute.

- DRIVE CONTROL BAR** - Used to engage tines.
- DEPTH STAKE** - Controls depth at which tiller will dig.
- OUTER SIDE SHIELD** - Adjustable to protect small plants from being buried.
- THROTTLE CONTROL** - Used to control engine speed.

- LEVELING SHIELD** - Levels tilled soil.
- SHIFT LEVER** - Used to shift transmission gears.
- SHIFT LEVER INDICATOR** - Shows what gear the transmission is in.
- RECOIL STARTER HANDLE** - Used to start the engine.



The operation of any tiller can result in foreign objects thrown into the eyes, which can result in severe eye damage. Always wear safety glasses or eye shields before starting your tiller and while tilling. We recommend a wide vision safety mask over spectacles or standard safety glasses.

HOW TO USE YOUR TILLER

Know how to operate all controls before adding fuel and oil or attempting to start engine.

STOPPING

TINES AND DRIVE

- Release drive control bar to stop movement.
- Move shift lever to "N" (neutral) position.

ENGINE

- Move throttle control to "STOP" position. If equipped with stop switch, move switch to "STOP" position.
- Never use choke to stop engine.

Drive Control Bar

"ENGAGED" Position

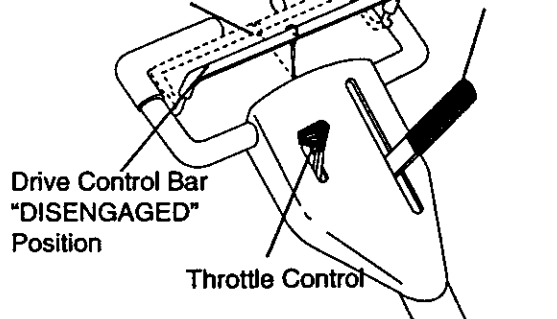

TINE OPERATION - WITH WHEEL DRIVE

- Always release drive control bar before moving shift lever into another position.
- Tine movement is achieved by moving shift lever to () till position and engaging drive control bar.

FORWARD - WHEELS ONLY/TINES STOPPED

- Release drive control bar and move shift lever indicator to "F" (forward) position. Engage drive control bar and tiller will move forward.

REVERSE - WHEELS ONLY/TINES STOPPED

- DO NOT STAND DIRECTLY BEHIND TILLER.
- Release the drive control bar.
- Move throttle control to "SLOW" position.
- Move shift lever indicator to "R" (reverse) position.
- Hold drive control bar against the handle to start tiller movement.

DEPTH STAKE

The depth stake can be raised or lowered to allow you more versatile tilling and cultivating, or to more easily transport your tiller.

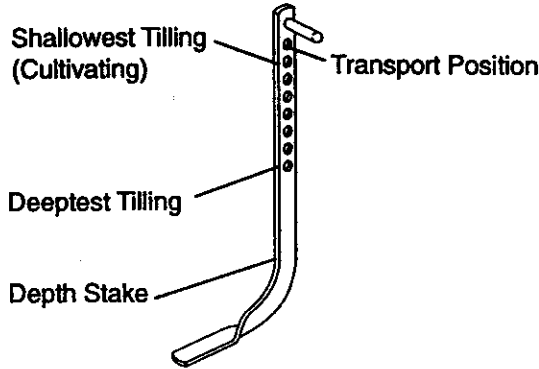

TILLING

- Release depth stake pin. Pull the depth stake up for increased tilling depth. Place depth stake pin in hole of depth stake to lock in position.
- Place shift lever indicator in till position.
- Hold the drive control bar against the handle to start tilling movement. Tines and wheels will both turn.
- Move throttle control to "FAST" position for deep tilling. To cultivate, throttle control can be set at any desired speed, depending on how fast or slow you wish to cultivate.

IMPORTANT: Always release drive control bar before moving shift lever into another position.

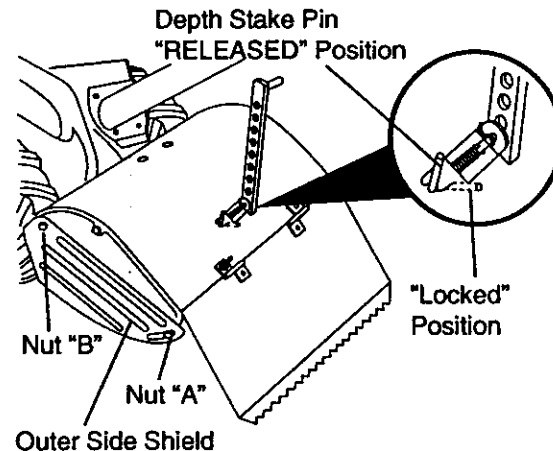

TURNING

- Release the drive control bar.
- Move throttle control to "SLOW" position.
- Place shift lever indicator in "F" (forward) position. Tines will not turn.
- Lift handle to raise tines out of ground.
- Swing the handle in the opposite direction you wish to turn, being careful to keep feet and legs away from tines.
- When you have completed your turnaround, release the drive control bar and lower handle. Place shift lever in till position and move throttle control to desired speed. To begin tilling, hold drive control bar against the handle.

OUTER SIDE SHIELDS

The back edges of the outer side shields are slotted so that the shields can be raised for deep tilling and lowered for shallow tilling to protect small plants from being buried. Loosen nut "A" in slot and nut "B". Move shield to desired position (both sides). Retighten nuts.

TO TRANSPORT

▲ CAUTION: Before lifting or transporting, allow tiller engine and muffler to cool. Disconnect spark plug wire. Drain gasoline from fuel tank.

AROUND THE YARD

- Release the depth stake pin. Move the depth stake down to the top hole for transporting the tiller. Place depth stake pin in hole of depth stake to lock in position. This prevents tines from scuffing the ground.
- Place shift lever indicator in "F" (forward) position for transporting.
- Hold the drive control bar against the handle to start tiller movement. Tines will not turn.
- Move throttle control to desired speed.

AROUND TOWN

- Disconnect spark plug wire.
- Drain fuel tank.
- Transport in upright position to prevent oil leakage.

BEFORE STARTING ENGINE

IMPORTANT: Be very careful not to allow dirt to enter the engine when checking or adding oil or fuel. Use clean oil and fuel and store in approved, clean, covered containers. Use clean fill funnels.

CHECK ENGINE OIL LEVEL

- The engine in your unit has been shipped, from the factory, already filled with SAE 30 summer weight oil.
- With engine level, clean area around oil filler plug and remove plug.
- Engine oil should be to point of overflowing when engine is level. For approximate capacity see "PRODUCT SPECIFICATIONS" on page 4 of this manual. All oil must meet A.P.I. Service Classification SF, SG or SH.
- Reinstall engine oil cap and tighten
- For cold weather operation you should change oil for easier starting (See oil viscosity chart in the Customer Responsibilities section of this manual).
- To change engine oil, see the Customer Responsibilities section in this manual.

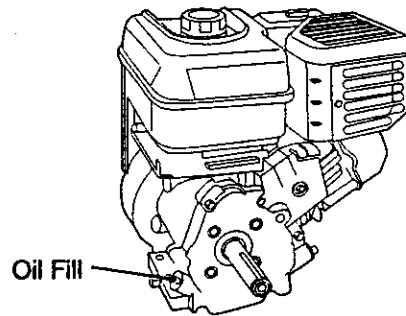

ADD GASOLINE

- Fill fuel tank. Use fresh, clean, regular unleaded gasoline. (Use of leaded gasoline will increase carbon and lead oxide deposits and reduce valve life.)
- IMPORTANT:** When operating in temperatures below 32°F (0°C), use fresh, clean, winter grade gasoline to help insure good cold weather starting.
- WARNING:** Experience indicates that alcohol blended fuels (called gasohol or using ethanol or methanol) can attract moisture which leads to separation and formation of acids during storage. Acidic gas can damage the fuel system of an engine while in storage. **To avoid engine problems, the fuel system should be emptied before storage of 30 days or longer.** Drain the gas tank, start the engine and let it run until the fuel lines and carburetor are empty. **Use fresh fuel next season.** See Storage section of this manual for additional information. Never use engine or carburetor cleaner products in the fuel tank or permanent damage may occur.

▲ CAUTION: Fill to within 1/2 inch of top of fuel tank to prevent spills and to allow for fuel expansion. If gasoline is accidentally spilled, move machine away from area of spill. Avoid creating any source of ignition until gasoline vapors have disappeared.

Do not overfill. Wipe off any spilled oil or fuel. Do not store, spill or use gasoline near an open flame.

TO START ENGINE

▲ CAUTION: Keep drive control bar in "DISENGAGED" position when starting engine.

When starting engine for the first time or if engine has run out of fuel, it will take extra pulls of the recoil starter to move fuel from the tank to the engine.

- Make sure spark plug wire is properly connected.
- Move shift lever indicator to "N" (neutral) position.
- Place throttle control in "FAST" position.
- Turn fuel shut-off valve 1/4 turn to OPEN position.
- Move choke control to CHOKE position.
- Grasp recoil starter handle with one hand and grasp tiller handle with other hand. Pull rope out slowly until engine reaches start of compression cycle (rope will pull slightly harder at this point).
- Pull recoil starter handle quickly. Do not let starter handle snap back against starter.
- If engine fires but does not start, move choke control to half choke position. Pull recoil starter handle until engine starts.
- When engine starts, slowly move choke control to "RUN" position as engine warms up.

NOTE: A warm engine requires less choking to start.

- Move throttle control to desired running position.
- Allow engine to warm up for a few minutes before engaging tines.

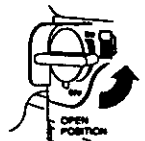

Fuel shut-off

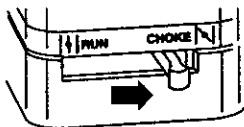

Choke controls

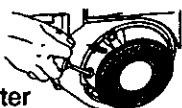

Rewind starter

NOTE: If at a high altitude (3000 feet) or in cold temperatures (below 40°F), the carburetor fuel mixture may need to be adjusted for best engine performance. See "TO ADJUST CARBURETOR" in the Service and Adjustments section of this manual.

NOTE: If engine does not start, see troubleshooting points.

TILLING HINTS

▲ CAUTION: Until you are accustomed to handling your tiller, start actual field use with throttle in slow position (mid-way between "FAST" and "IDLE").

- Tilling is digging into, turning over, and breaking up packed soil before planting. Loose, unpacked soil helps root growth. Best tilling depth is 4" to 6". A tiller will also clear the soil of unwanted vegetation. The decomposition of this vegetable matter enriches the soil. Depending on the climate (rainfall and wind), it may be advisable to till the soil at the end of the growing season to further condition the soil.
- Soil conditions are important for proper tilling. Tines will not readily penetrate dry, hard soil which may contribute to excessive bounce and difficult handling of your tiller. Hard soil should be moistened before tilling; however, extremely wet soil will "ball-up" or clump during tilling. Wait until the soil is less wet in order to achieve the best results. When tilling in the fall, remove vines and long grass to prevent them from wrapping around the tine shaft and slowing your tilling operation.
- You will find tilling much easier if you leave a row untilled between passes. Then go back between tilled rows. There are two reasons for doing this. First, wide turns are much easier to negotiate than about-faces. Second, the tiller won't be pulling itself, and you, toward the row next to it.
- Do not lean on handle. This takes weight off the wheels and reduces traction. To get through a really tough section of sod or hard ground, apply upward pressure on handle or lower the depth stake.

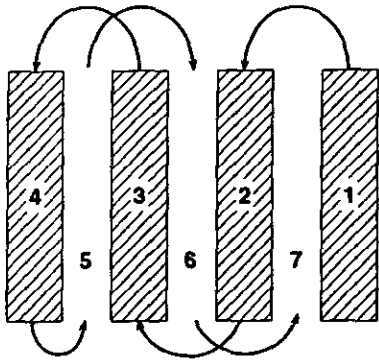

CULTIVATING

Cultivating is destroying the weeds between rows to prevent them from robbing nourishment and moisture from the plants. At the same time, breaking up the upper layer of soil crust will help retain moisture in the soil. Best digging depth is 1" to 3" (2.5-7.5 cm). Lower the outer side shields to protect small plants from being buried.

- Cultivate up and down the rows at a speed which will allow tines to uproot weeds and leave the ground in rough condition, promoting no further growth of weeds and grass.

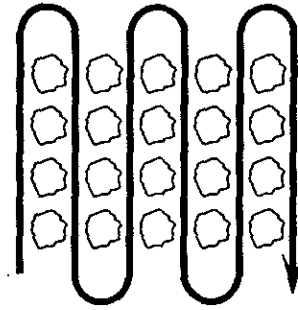

TINE SHEAR PINS

The tine assemblies on your tiller are secured to the tine shaft with shear pins (See "TINE REPLACEMENT" in the Service and Adjustments section of this manual).

If the tiller is unusually overloaded or jammed, the shear pins are designed to break before internal damage occurs to the transmission.

- If shear pin(s) break, replace only with those shown in the Repair Parts section of this manual.

MAINTENANCE

MAINTENANCE SCHEDULE	SERVICE DATES											
FILL IN DATES AS YOU COMPLETE REGULAR SERVICE	BEFORE EACH USE	EVERY 5 HOURS	EVERY 25 HOURS	EVERY 50 HOURS								
Check Engine Oil Level	✓	✓										
Change Engine Oil			✓ _{1,2}									
Oil Pivot Points		✓										
Inspect Spark Arrester / Muffler			✓									
Inspect Air Screen	✓											
Clean or Replace Air Cleaner Cartridge			✓ ₂									
Clean Engine Cylinder Fins			✓									
Replace Spark Plug			✓									

- 1 - Change more often when operating under a heavy load or in high ambient temperatures.
 2 - Service more often when operating in dirty or dusty conditions.

GENERAL RECOMMENDATIONS

The warranty on this tiller does not cover items that have been subjected to operator abuse or negligence. To receive full value from the warranty, the operator must maintain tiller as instructed in this manual. Some adjustments will need to be made periodically to properly maintain your tiller. All adjustments in the Service and Adjustments section of this manual should be checked at least once each season.

- Once a year you should replace the spark plug, clean or replace air filter, and check tines and belts for wear. A new spark plug and clean air filter assure proper air-fuel mixture and help your engine run better and last longer.

BEFORE EACH USE

- Check engine oil level.
- Check tine operation.
- Check for loose fasteners.

LUBRICATION

Keep unit well lubricated (See "LUBRICATION CHART").

LUBRICATION CHART

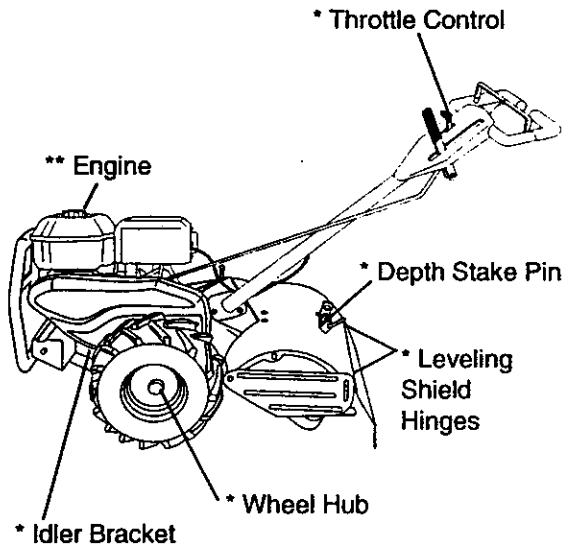

- * SAE 30 OR 10W-30 MOTOR OIL
- ** REFER TO CUSTOMER RESPONSIBILITIES "ENGINE" SECTION

Disconnect spark plug wire before performing any maintenance (except carburetor adjustment) to prevent accidental starting of engine.

Prevent fires! Keep the engine free of grass, leaves, spilled oil, or fuel. Remove fuel from tank before tipping unit for maintenance. Clean muffler area of all grass, dirt, and debris.

Do not touch hot muffler or cylinder fins as contact may cause burns.

ENGINE LUBRICATION

Use only high quality detergent oil rated with API service classification SF, SG or SH. Select the oil's SAE viscosity grade according to your expected temperature.

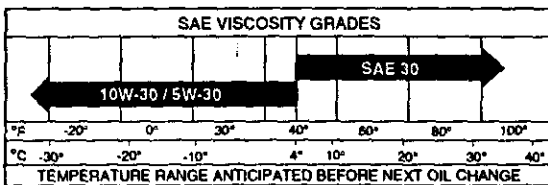

NOTE: Although multi-viscosity oils (5W-30, 10W-30, etc.) improve starting in cold weather, these multi-viscosity oils will result in increased oil consumption when used above 40°F (4°C). Check your engine oil level more frequently to avoid possible engine damage from running low on oil.

Change the oil after every 50 hours of operation or at least once a year if the tiller is not used for 50 hours in one year.

Check the crankcase oil level before starting the engine and after each five (5) hours of continuous use. Add SAE 30 motor oil or equivalent. Tighten oil filler plug securely each time you check the oil level.

TO CHANGE ENGINE OIL

Determine temperature range expected before oil change. All oil must meet API service classification SF, SG or SH.

- Be sure tiller is on level surface.
- Oil will drain more freely when warm.
- Use a funnel to prevent oil spill on tiller, and catch oil in a suitable container.
- Remove oil drain plug. Be careful not to allow dirt to enter the engine. For easier removal of plug use 7/16 12 Pt. socket with extension.
- Tip tiller forward to drain oil.

- After oil has drained completely, replace oil drain plug and tighten securely.
- Remove oil fill plug.
- Refill engine with oil through oil fill tube. See "CHECK ENGINE OIL LEVEL" in the Operation section of this manual.
- Replace oil fill plug and tighten securely.

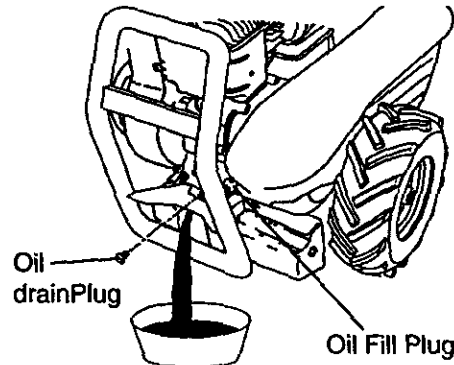

AIR FILTER

Your engine will not run properly using a dirty air filter. Clean the foam pre-cleaner after every 50 hours of operation or every season. Service paper cartridge every 100 hours of operation or every season, whichever occurs first.

Service air cleaner more often under dust conditions.

- Remove knob and cover. Lift air cleaner assembly off stud.

TO SERVICE PRE-CLEANER

- Remove foam pre-cleaner from air filter
- Wash it in liquid detergent and water.
- Squeeze it dry in a clean cloth.
- If very dirty or damaged, replace pre-cleaner.
- Reinstall pre-cleaner onto air filter.
- Reinstall cover and secure with knob.

TO SERVICE CARTRIDGE

- Carefully remove cartridge to prevent debris from entering carburetor. Clean base carefully to prevent debris from entering carburetor.
- Remove foam pre-cleaner from air filter
- Clean cartridge by tapping gently on flat surface. If very dirty or damaged, replace cartridge.
- Reinstall pre-cleaner onto air filter.
- Reinstall cover and secure with knob.

IMPORTANT: Petroleum solvents, such as kerosene, are not to be used to clean the cartridge. They may cause deterioration of the cartridge. Do not oil cartridge. Do not use pressurized air to clean or dry cartridge.

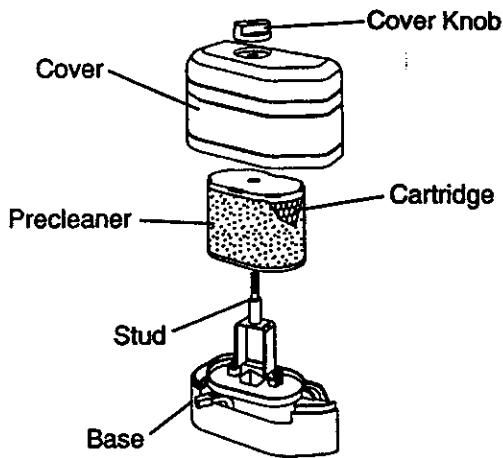

COOLING SYSTEM

Your engine is air cooled. For proper engine performance and long life keep your engine clean.

- Clean air screen frequently using a stiff-bristled brush.
- Keep cylinder fins, levers, and linkage free of dirt and chaff.

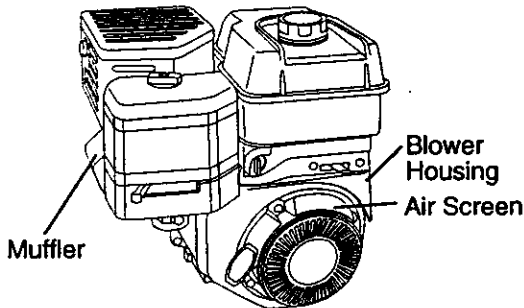

MUFFLER

Do not operate tiller without muffler. Do not tamper with exhaust system. Damaged mufflers or spark arresters could create a fire hazard. Inspect periodically and replace if necessary. If your engine is equipped with a spark arrester screen assembly, remove every 50 hours for cleaning and inspection. Replace if damaged.

SPARK PLUG

Replace spark plugs at the beginning of each tilling season or after every 50 hours of use, whichever comes first. Spark plug type and gap setting is shown in "PRODUCT SPECIFICATIONS" on page 4 of this manual.

TRANSMISSION

Your transmission is sealed and will only require lubrication if serviced.

CLEANING

- Clean engine, wheels, finish, etc. of all foreign matter.
- Keep finished surfaces and wheels free of all gasoline, oil, etc.
- Protect painted surfaces with automotive type wax.

We do not recommend using a garden hose to clean your unit unless the muffler, air filter and carburetor are covered to keep water out. Water in engine can result in a shortened engine life.

SERVICE AND ADJUSTMENTS

CAUTION: Disconnect spark plug wire from spark plug and place wire where it cannot come into contact with plug.

TILLER

TO ADJUST HANDLE HEIGHT

Select handle height best suited for your tilling conditions. Handle height will be different when tiller digs into soil.

- First loosen handle lock lever. (Do not loosen too much or handle locks may fall out.)
- Handle can be positioned at different settings between "HIGH" and "LOW" positions.
- Retighten handle lock lever securely after adjusting.

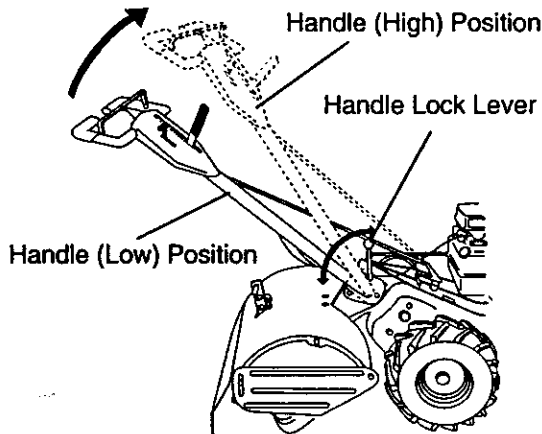

TIRE CARE

CAUTION: When mounting tires, unless beads are seated, overinflation can cause an explosion.

- Maintain 20 pounds of tire pressure. If tire pressures are not equal, tiller will pull to one side.
- Keep tires free of gasoline or oil which can damage rubber.

TO REMOVE WHEEL

- Place blocks under transmission to keep tiller from tipping.
- Remove outer side shield by removing nuts "A" and "B".
- Remove inner side shield by removing nuts "C" and "D".
- Remove hairpin clip and clevis pin from wheel.
- Remove wheel and tire. • Repair tire and reassemble.

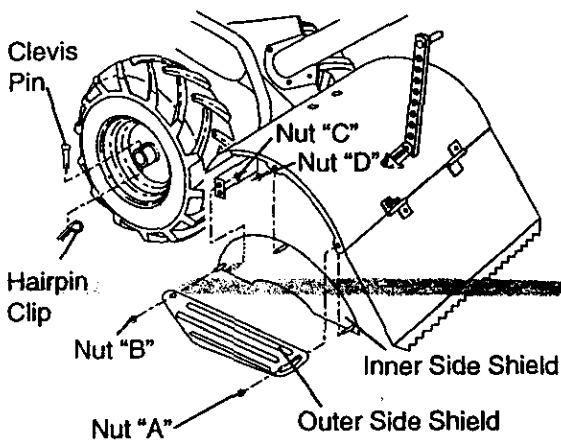

TO REMOVE BELT GUARD

- NOTE:** For ease of removal, remove hairpin clip and clevis pin from left wheel. Pull wheel out from tiller about 1 inch.
- Remove two (2) screws, one (1) nut and washer from side of belt guard.
 - Pull belt guard out and away from unit.
 - Replace belt guard by reversing above procedure.

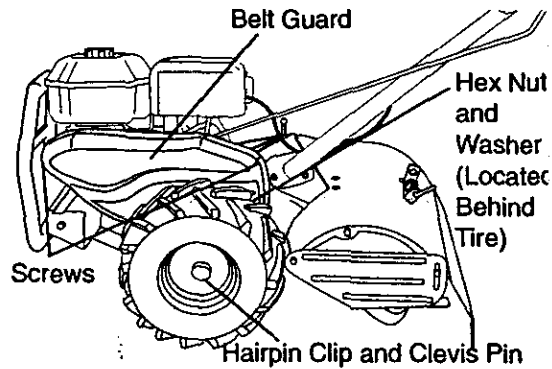

TO REPLACE GROUND DRIVE BELT

- Remove belt guard as described in "TO REMOVE BELT GUARD".
- Remove old belt by slipping off engine pulley first then remove from transmission pulley.
- Place new belt in groove of transmission pulley and into engine pulley. BELT MUST BE IN GROOVE ON TOP OF IDLER PULLEY. NOTE POSITION OF BELT TO GUIDES.
- Check belt adjustment as described below.
- Replace belt guard.
- Reposition wheel and replace clevis pin and hairpin clip.

GROUND DRIVE BELT ADJUSTMENT

For proper belt tension, the extension spring should have about 5/8 inch stretch when drive control bar is in "ENGAGED" position. This tension can be attained as follows:

- Loosen cable clip screw securing the drive control cable.
- Slide cable forward for less tension and rearward for more tension until about 5/8 inch stretch is obtained while the drive control bar is engaged.
- Tighten cable clip screw securely.

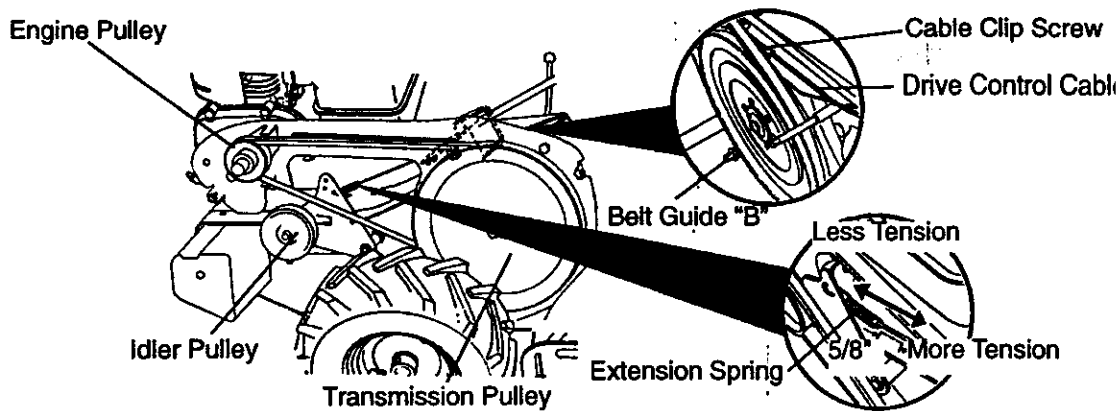

TINE REPLACEMENT

CAUTION: Tines are sharp. Wear gloves or other protection when handling tines.

A badly worn tine causes your tiller to work harder and dig more shallow. Most important, worn tines cannot chop and shred organic matter as effectively nor bury it as deeply as good tines. A tine this worn needs to be replaced.

- To maintain the superb tilling performance of this machine the tines should be checked for sharpness, wear, and bending, particularly the tines which are next to the transmission. If the gap between the tines exceeds 3-1/2 inches they should be replaced or straightened as necessary.
- New tines should be assembled. Sharpened tine edges will rotate rearward from above.

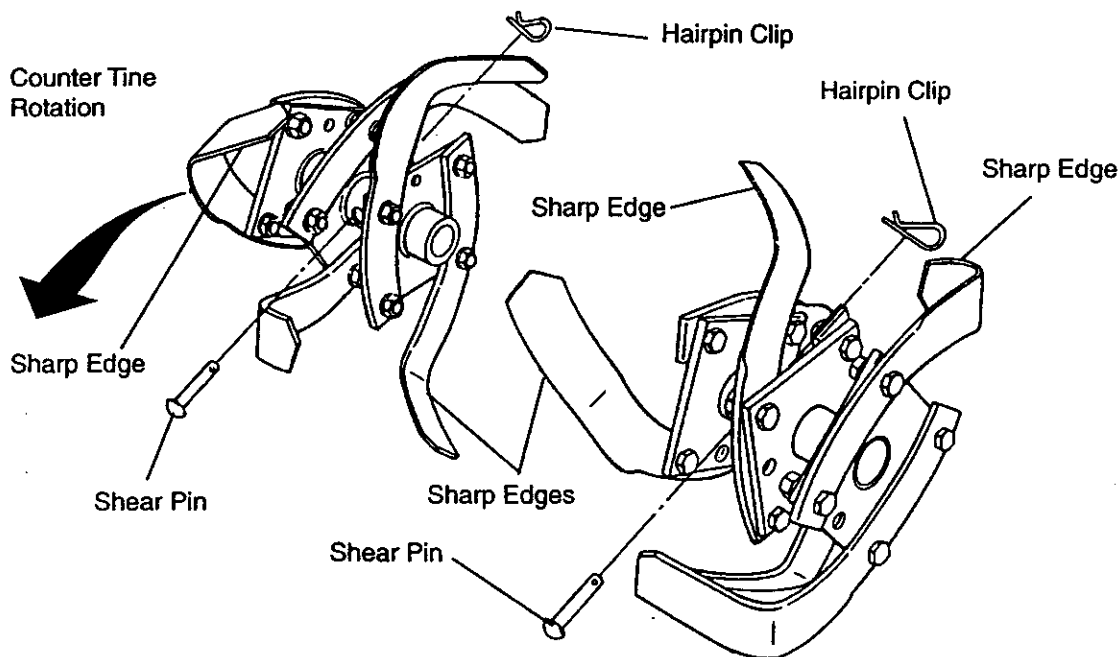
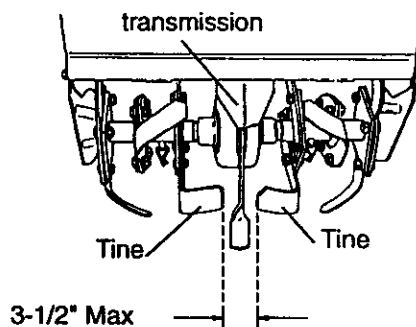
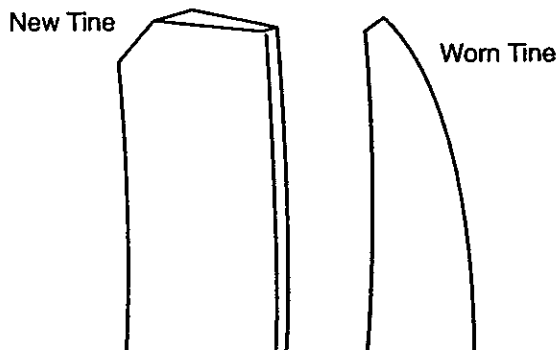

ENGINE

Maintenance, repair, or replacement of the emission control devices and systems, which are being done at the customer's expense, may be performed by any non-road engine repair establishment or individual. Warranty repairs must be performed by an authorized engine manufacturer's service outlet.

TO ADJUST THROTTLE CONTROL CABLE

- The throttle control has been preset at the factory and adjustment should not be necessary. If adjustment is necessary, proceed as follows:
- With engine not running, move remote throttle control lever to "FAST" position.
- If throttle lever on engine touches high speed stop, no further adjustment is necessary. If throttle lever does not touch high speed stop, continue with adjustment procedure.
- Loosen cable clamp screw.
- Move throttle lever up until it touches high speed stop, and hold in this position.
- Tighten cable clamp screw securely.

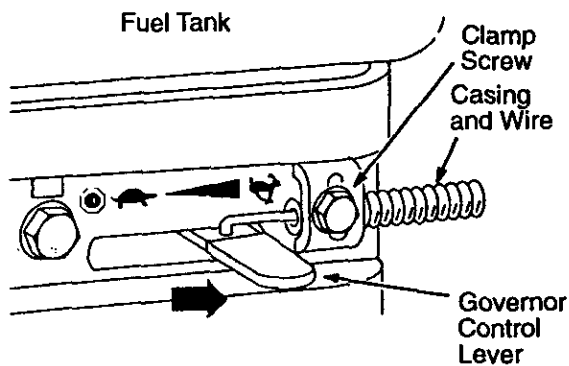

TO ADJUST CARBURETOR

The carburetor has been preset at the factory and adjustment should not be necessary. However, engine performance can be affected by differences in fuel, temperature, altitude or load. If the carburetor does need adjustment, contact your nearest authorized service center/department **IMPORTANT:** Never tamper with the engine governor, which is factory set for proper engine speed. Overspeeding the engine above the factory high speed setting can be dangerous. If you think the engine-governed high speed needs adjusting, contact your nearest authorized service center/department, which has the proper equipment and experience to make any necessary adjustments.

STORAGE

Immediately prepare your tiller for storage at the end of the season or if the unit will not be used for 30 days or more.

▲ CAUTION: Never store the tiller with gasoline in the tank inside a building where fumes may reach an open flame or spark. Allow the engine to cool before storing in any enclosure.

TILLER

- Clean entire tiller (See "CLEANING" in the Maintenance section of this manual).
- Inspect and replace belts, if necessary (See belt replacement instructions in the Service and Adjustments section of this manual).
- Lubricate as shown in the Maintenance section of this manual.
- Be sure that all nuts, bolts and screws are securely fastened. Inspect moving parts for damage, breakage and wear. Replace if necessary.
- Touch up all rusted or chipped paint surfaces; sand lightly before painting.

ENGINE

FUEL SYSTEM

IMPORTANT: It is important to prevent gum deposits from forming in essential fuel system parts such as the carburetor, fuel filter, fuel hose, or tank during storage. also, experience indicates that alcohol blended fuels (called gasohol or using ethanol or methanol) can attract moisture which leads to separation and formation of acids during storage. Acidic gas can damage the fuel system of an engine while in storage.

- Drain the fuel tank.
- Start the engine and let it run until the fuel lines and carburetor are empty.
- Never use engine or carburetor cleaner products in the fuel tank or permanent damage may occur.
- Use fresh fuel next season.

NOTE: Fuel stabilizer is an acceptable alternative in minimizing the formation of fuel gum deposits during storage. Add stabilizer to gasoline in fuel tank or storage container. Always follow the mix ratio found on stabilizer container. Run engine at least 10 minutes after adding stabilizer to allow the stabilizer to reach the carburetor. Do not drain the gas tank and carburetor if using fuel stabilizer.

ENGINE OIL

Drain oil (with engine warm) and replace with clean oil. (See "ENGINE" in the Maintenance section of this manual).

CYLINDER(S)

- Remove spark plug.
- Pour 1 ounce (29 ml) of oil through spark plug hole into cylinder.
- Pull starter handle slowly several times to distribute oil.
- Replace with new spark plug.

OTHER

- Do not store gasoline from one season to another.
- Replace your gasoline can if your can starts to rust. Rust and/or dirt in your gasoline will cause problems.
- If possible, store your unit indoors and cover it to give protection from dust and dirt.
- Cover your unit with a suitable protective cover that does not retain moisture. Do not use plastic. Plastic cannot breathe which allows condensation to form and will cause your unit to rust.

IMPORTANT: Never cover tiller while engine and exhaust areas are still warm.

TROUBLE SHOOTING

PROBLEM	CAUSE	CORRECTION
Will not start	<ol style="list-style-type: none"> 1. Out of fuel. 2. Engine not "CHOKED" properly. 3. Engine flooded. 4. Dirty air cleaner. 5. Water in fuel. 6. Clogged fuel tank. 7. Loose spark plug wire. 8. Bad spark plug or improper gap. 9. Carburetor out of adjustment. 	<ol style="list-style-type: none"> 1. Fill fuel tank. 2. See "TO START ENGINE" in the Operation section. 3. Wait several minutes before attempting to start. 4. Clean or replace air cleaner cartridge. 5. Drain fuel tank and carburetor, and refill tank with fresh gasoline. 6. Remove fuel tank and clean. 7. Make sure spark plug wire is seated properly on plug. 8. Replace spark plug or adjust gap. 9. Make necessary adjustments.
Hard to start	<ol style="list-style-type: none"> 1. Throttle control not set properly. 2. Dirty air cleaner. 3. Bad spark plug or improper gap. 4. Stale or dirty fuel. 5. Loose spark plug wire. 6. Carburetor out of adjustment. 	<ol style="list-style-type: none"> 1. Place throttle control in "FAST" position. 2. Clean or replace air cleaner cartridge. 3. Replace spark plug or adjust gap. 4. Drain fuel tank and refill with fresh gasoline. 5. Make sure spark plug wire is seated properly on plug. 6. Make necessary adjustments.
Loss of power	<ol style="list-style-type: none"> 1. Engine is overloaded. 2. Dirty air cleaner. 3. Low oil level/dirty oil. 4. Faulty spark plug. 5. Oil in fuel. 6. Stale or dirty fuel. 7. Water in fuel. 8. Clogged fuel tank. 9. Spark plug wire loose. 10. Dirty engine air screen. 11. Dirty/clogged muffler. 12. Carburetor out of adjustment. 13. Poor compression. 	<ol style="list-style-type: none"> 1. Set depth stake and wheels for shallower tilling. 2. Clean or replace air cleaner cartridge. 3. Check oil level/change oil. 4. Clean and regap or change spark plug. 5. Drain and clean fuel tank and refill, and clean carburetor. 6. Drain fuel tank and refill with fresh gasoline. 7. Drain fuel tank and carburetor, and refill tank with fresh gasoline. 8. Remove fuel tank and clean. 9. Connect and tighten spark plug. 10. Clean engine air screen. 11. Clean/replace muffler. 12. Make necessary adjustments. 13. Contact an authorized Sears Service Center/Department.

PROBLEM	CAUSE	CORRECTION
Engine overheats	<ol style="list-style-type: none"> 1. Low oil level/dirty oil. 2. Dirty engine air screen. 3. Dirty engine. 4. Partially plugged muffler. 5. Improper carburetor adjustment. 	<ol style="list-style-type: none"> 1. Check oil level/change oil. 2. Clean engine air screen. 3. Clean cylinder fins, air screen, muffler area. 4. Remove and clean muffler. 5. Adjust carburetor to richer position.
Excessive bounce/difficult handling	<ol style="list-style-type: none"> 1. Ground too dry and hard. 2. Wheels and depth stake incorrectly adjusted. 	<ol style="list-style-type: none"> 1. Moisten ground or wait for more favorable soil conditions. 2. Adjust wheels and depth stake.
Soil balls up or clumps	<ol style="list-style-type: none"> 1. Ground too wet. 	<ol style="list-style-type: none"> 1. Wait for more favorable soil conditions.
Engine runs but tiller won't move	<ol style="list-style-type: none"> 1. Tine control is not engaged. 2. V-belt not correctly adjusted. 3. V-belt is off pulley(s). 	<ol style="list-style-type: none"> 1. Engage tine control. 2. Inspect/adjust V-belt. 3. Inspect V-belt.
Engine runs but labors when tilling	<ol style="list-style-type: none"> 1. Tilling too deep. 2. Throttle control not properly adjusted. 3. Carburetor out of adjustment. 	<ol style="list-style-type: none"> 1. Set depth stake for shallower tilling. 2. Check throttle control setting. 3. Make necessary adjustments.

REPAIR PARTS

TILLER - MODEL NUMBER 917.293310

HANDLES

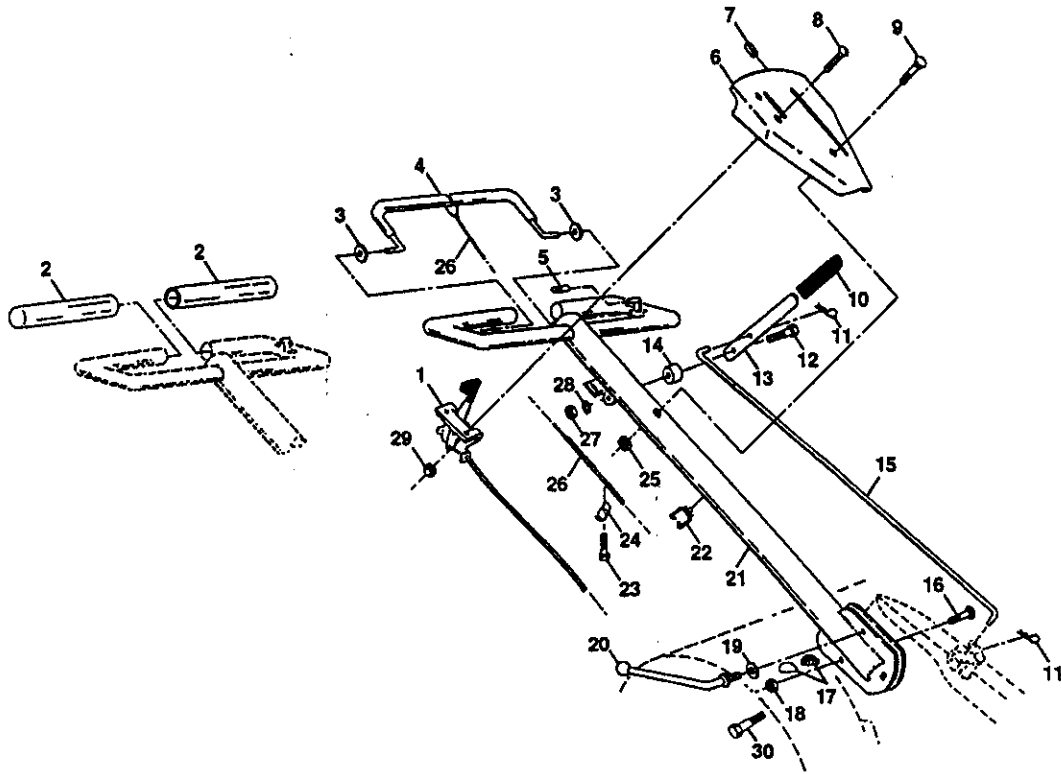

KEY PART NO. NO.

NO.	NO.	DESCRIPTION
1	164743	Throttle, Control
2	141406	Grip, Handle
3	110673X	Grommet, Handle
4	127254X	Bar, Drive Control Assembly
5	6712J	Cap, Vinyl
6	137119	Panel, Control
7	110641X	Bushing, Split
8	71191008	*Screw, Pan Head #10-24
9	72010520	*Bolt, 5/16-18 x 2-1/2
10	110646X	Handle, Grip
11	STD624003	*Clip, Hairpin
12	81328	Bolt, Shoulder
13	110741X	Handle, Shift
14	109313X	Grommet, Rubber
15	110702X	Rod, Shift
16	STD533710	*Bolt, Carriage 3/8-16 x 1 Gr. 5
17	109229X	Lock, Handle

KEY PART NO. NO.

NO.	NO.	DESCRIPTION
18	STD541437	*Nut, Centerlock 3/8-16
19	19131611	Washer 13/32 x 1 x 11 Ga.
20	109228X	Lever, Lock, Handle
21	150258	Handle, Assemble
22	165197	Clip, Plastic, Cable
23	86777	Screw, Hex, Washer Hd, Slotted #10-24 x 1/2
24	9484R	Clip
25	73970500	Locknut, Hex, Flange
26	110675X	Clutch, Cable
27	STD541025	*Nut, Hex 1/4-20
28	STD551125	*Washer, Lock 1/4
29	STD541462	*Nut, Keps #10-24
30	150696	Bolt, Pivot

* STANDARD HARDWARE - - PURCHASE LOCALLY
NOTE: All component dimensions given in U.S. inches.
1 inch = 25.4 mm

TILLER - - MODEL NUMBER 917.293310

MAINFRAME, LEFT SIDE

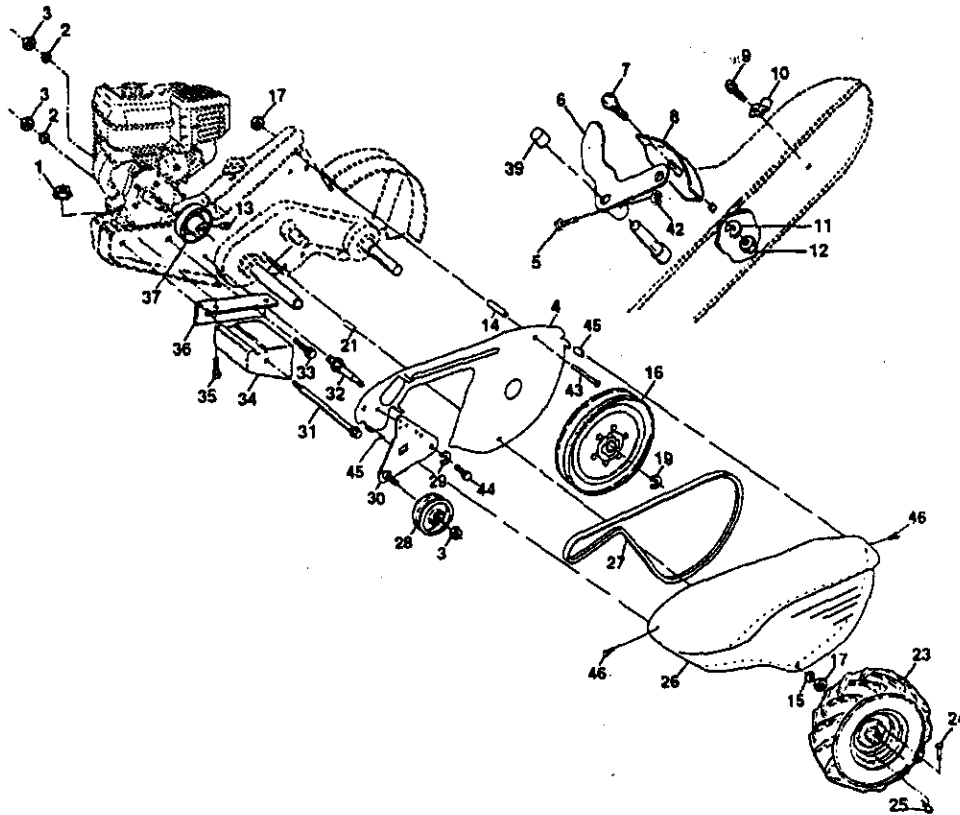

KEY PART

NO.	NO.	DESCRIPTION
1	STD541431	Nut, Keps 5/16-18
2	STD551137	*Washer, Lock 3/8
3	STD541037	*Nut, Hex 3/8-16
4	165710	Shield, Inner Belt, Guard
5	154734	Screw Shift Lever
6	110111X	Lever, Shift
7	STD532505	*Bolt, Carriage 1/4-20 x 1/2 Gr. 5
8	8700J	Plate, Shift Indicator
9	86777	Screw, Hex, Washer Head, Slotted #10-24 x 1/2
10	9484R	Clip
11	STD551125	*Washer, Lock 1/4
12	STD541025	*Nut, Hex 1/4-20
13	23230506	*Screw, Set, 5/16-18 x 3/8
14	110652X	Spacer, Split .327 x .42 x 2.09
15	STD551031	*Washer 11/32 x 11/16 x 16 Ga.
16	145102	Sheave, Transmission
17	STD541031	*Nut, Hex 5/16-18
19	12000028	Ring, Retainer
21	156117	Spacer, Split .327 x .42 x 1.220
23	5015J	Tire
	128952	Rim
	795R	Tire Valve

KEY PART

NO.	NO.	DESCRIPTION
24	126875X	Rivet, Drilled
25	STD624003	*Clip, Hairpin
26	165501X558	Guard, Belt
27	132801	Belt, V
28	104679X	Pulley, Idler
29	12000032	Ring, Klip
30	159229	Bracket, Idler
31	102384X	Bolt, Hex 5/16-16 x 12
32	102141X	Shaft, Idler Arm
33	STD523710	*Bolt, Hex 3/8-16 x 1
34	102383X	Counterweight, L.H.
35	STD523120	Bolt, Hex 5/16-18 x 1 1/2
36	102331X	Bracket, Reinforcement, L.H.
37	130812	Sheave, Engine
39	140062	Cap, Plunger
42	69180	Nut Lock #10-24
43	74760544	Bolt, Fin Hex 5/16-18 x 2-3/4
44	74770508	Belt, Fin Hex 5/16-24 x 1/2
45	165504	Nut, J Clip #8
46	165503	Screw Hex Wsh. Hd #8-18 x 1/2

*STANDARD HARDWARE - - PURCHASE LOCALLY
 NOTE: All component dimensions given in U.S. inches.
 1 inch = 25.4 mm

MAINFRAME, RIGHT SIDE

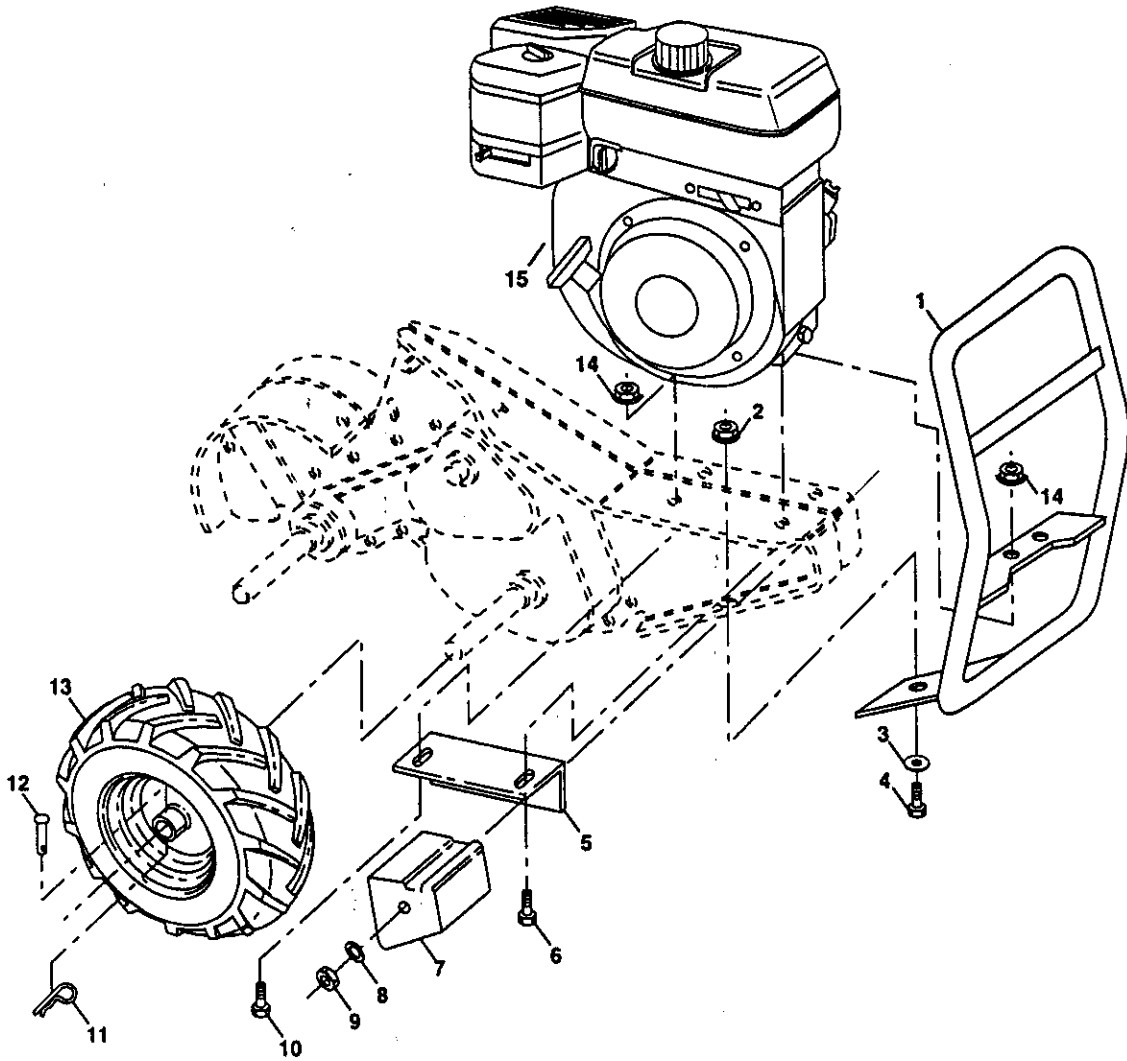

KEY PART

NO.	NO.	DESCRIPTION
1	166532	Bumper
2	73970500	Locknut, Hex, Flange 5/16-18
3	STD551031	*Washer 11/32 x 11/16 x 16Ga.
4	STD523107	Bolt, Hex 5/16-18 x 3/4
5	102332X	Bracket, Reinforcement
6	STD523120	Bolt, Hex 5/16-18 x 2
7	102173X	Counter Weight, R.H.
8	STD551137	*Washer, Lock 3/8
9	STD541037	*Nut, Hex 3/8-16
10	74760524	Bolt, Hex 5/16-18 x 1-1/2

KEY PART

NO.	NO.	DESCRIPTION
11	STD624003	*Clip, Hairpin
12	126875X	Rivet, Drilled
13	5015J	Tire
	128952	Rim
	795R	Tire Valve
14	STD541431	*Nut, Keps 5/16-18
15	-----	Engine, (See Breakdown) Craftsman Model No. 121432-0124-E1

STANDARD HARDWARE -- PURCHASE LOCALLY

NOTE: All component dimensions given in U.S.inches.
1 inch = 25.4 mm

TILLER - - MODEL NUMBER 917.293310

TRANSMISSION

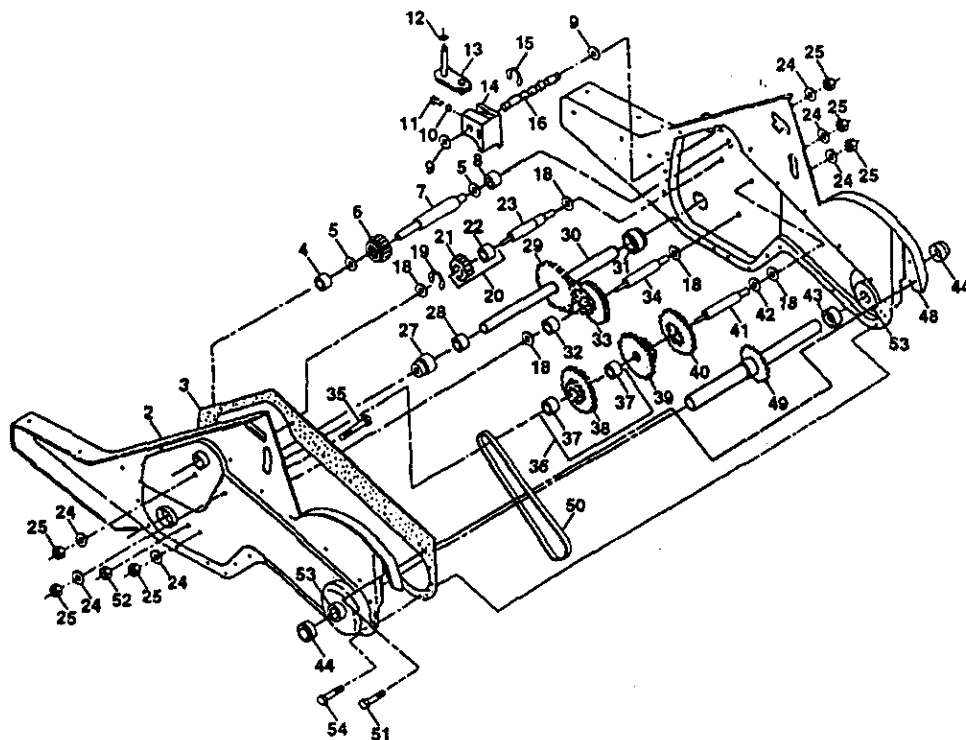

KEY PART

NO.	NO.	DESCRIPTION
1	165728	Transmission Assembly (Includes Key Nos. 2-52)
2	165729	Gearcase, L.H. w/Bearing (Includes Key No. 4)
3	161963	Gasket, Gearcase
4	5020J	Bearing, Needle
5	1370H	Washer, Thrust 5/8 x 1.10 x 1/32
6	137335	Pinion, Input
7	145101	Shaft, Input
8	4895H	Bearing, Needle
9	154467	Washer, Seal
10	7392M	Ball, Steel
11	100371K	Spring, Shift, Fork
12	106160X	O-Ring
13	142145	Arm, Shift
14	8353J	Fork, Shift
15	12000039	Ring, Klip
16	154466	Shaft, Shift
18	4358J	Washer
19	12000040	Ring, Klip
20	102114X	Gear, Assembly, Reverse Idler (Includes Key Nos. 21 and 22)
21	102115X	Gear, Reverse Idler
22	6803J	Bearing, Needle
23	102111X	Shaft, Reverse Idler
24	STD551143	*Washer, Lock 7/16
25	STD541143	*Nut, Hex 7/16-20
27	143009	Bearing, Shaft, Ground Drive L.H.
28	106390X	Spacer 0.765 x 1.125 x 1.23
29	102134X	Chain #35-50 Pitch

KEY PART

NO.	NO.	DESCRIPTION
30	150737	Ground Shaft Assembly
31	143008	Bearing, Shaft, Ground Drive R.H.
32	106388X	Spacer 0.70 x 1.00 x 1.150
33	102121X	Sprocket and Gear Assembly
34	102112X	Shaft, Reduction (2nd)
35	102101X	Screw, Whiz, Lock 5/16-18 x 3-1/2
36	154355	Sprocket Assembly w/Bearing (Includes Key Nos. 37 and 38)
37	4422J	Bearing, Needle
38	154356	Sprocket, Tine
39	105345X	Gear, Cluster, Red 1st & 2nd
40	105346X	Gear, Reverse
41	8358J	Shaft, Reduction (1st)
42	4220R	Washer, Thrust
43	106146X	Spacer 1.01 x 1.75 x 0.760
44	155236	Seal Asm. Oil
48	165732	Gearcase, R.H. w/Bearing (Includes Key No. 8)
49	132688	Shaft, Tine
50	106147X	Chain, Roller #50-50 Pitch
51	17720408	Screw 1/4-20 x 1/2
52	STD541031	*Nut, Hex 5/16-18
53	165140	Bearing Kit, Tine Shaft
54	17720412	Screw 1/4-20 x 3/4
--	6066J	Grease, Plastilube #1

* STANDARD HARDWARE - - PURCHASE LOCALLY
 NOTE: All component dimensions given in U.S.inches.
 1 inch = 25.4 mm

TILLER - - MODEL NUMBER 917.293310

TINE SHIELD

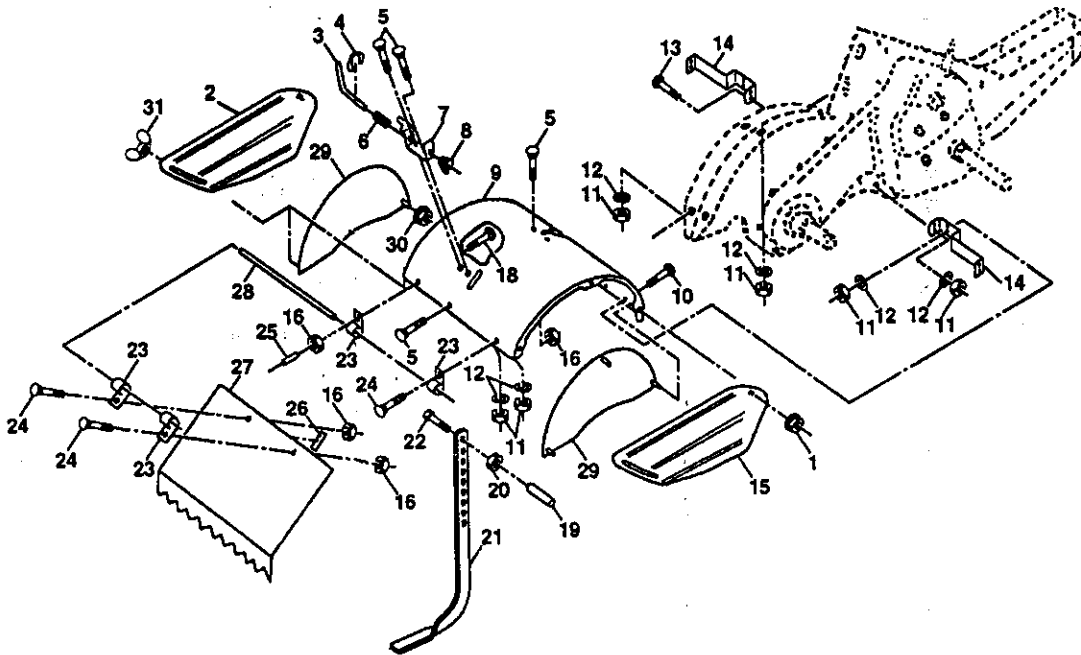

KEY PART

NO.	NO.	DESCRIPTION
1	98000129	Nut, Flange 5/16-18
2	161415X558	Shield, Side, Outer L. H.
3	8393J	Pin, Stake, Depth
4	12000036	Ring, Klip
5	STD533107	*Bolt, Carriage 5/16-18 x 3/4 Gr 5
6	8394J	Spring
7	8392J	Bracket, Latch
8	109230X	Spring, Depth Stake
9	124289X558	Shield, Tine
10	STD533110	*Bolt, Carriage 5/16-18 x 1 Gr. 5
11	STD541031	*Nut, Hex 5/16-18
12	STD551131	*Washer, Lock 5/16
13	STD533112	Bolt, Carriage 5/16-18 x 1-1/4
14	124311X	Bracket, Shield Tine
15	161414X558	Shield, Side, Outer R.H.
16	73510400	Nut, Hex 1/4-20

KEY PART

NO.	NO.	DESCRIPTION
18	STD532512	*Bolt, Carriage 1/4-20 x 1-1/4 Gr. 5
19	102701X	Grip
20	STD541037	*Nut, Hex 3/8-16
21	102156X	Stake, Depth
22	74930632	Bolt, Hex 3/8-16 x 2
23	4440J	Hinge
24	STD532505	*Bolt, Carriage 1/4-20 x 1/4
25	6712J	Cap, Vinyl
26	109227X	Pad, Idler
27	102695X558	Shield, Leveling
28	120588X	Pin, Hinge
29	124309X558	Shield, Side
30	73970500	Locknut, Hex, Flange
31	162175	Nut, Wing Forged 5/16-18

* STANDARD HARDWARE - - PURCHASE LOCALLY
 NOTE: All component dimensions given in U.S. inches
 1 inch = 25.4 mm

TILLER - - MODEL NUMBER 917.293310

TINE ASSEMBLY

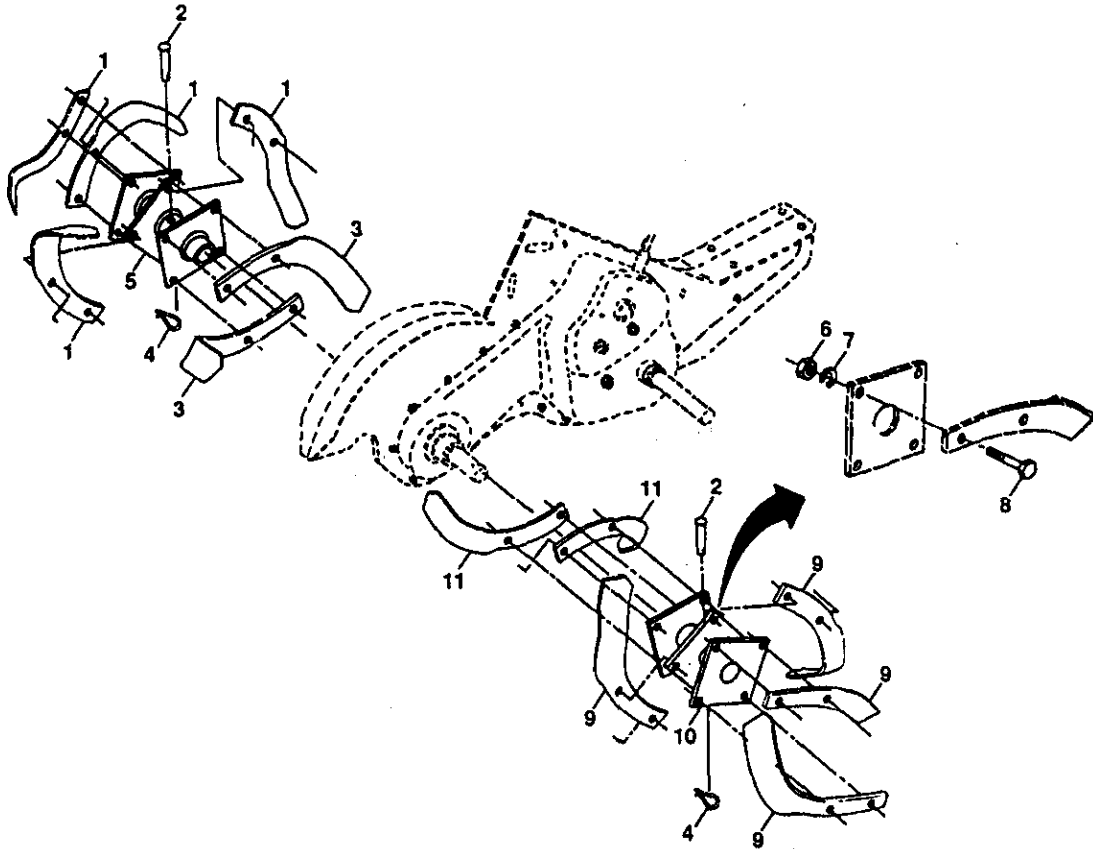

KEY PART		
NO.	NO.	DESCRIPTION
1	4459J	Tine, Outer, L.H.
2	132673	Pin, Shear
3	6554J	Tine, Inner, L.H.
4	163552	*Clip, Hairpin
5	132727	Assembly, Hub and Plate, L.H.
6	73610600	Nut, Hex 3/8-24
7	STD551137	*Washer, Lock 3/8
8	74610616	Bolt, Hex 3/8-24 x 1

KEY PART		
NO.	NO.	DESCRIPTION
9	4460J	Tine, Outer, R.H.
10	132728	Assembly, Hub and Plate, R.H.
11	6555J	Tine, Inner, R.H.

* STANDARD HARDWARE - - PURCHASE LOCALLY
 NOTE: All component dimensions given in U.S. inches.
 1 inch = 25.4 mm

TILLER - - MODEL NUMBER 917.293310

DECALS

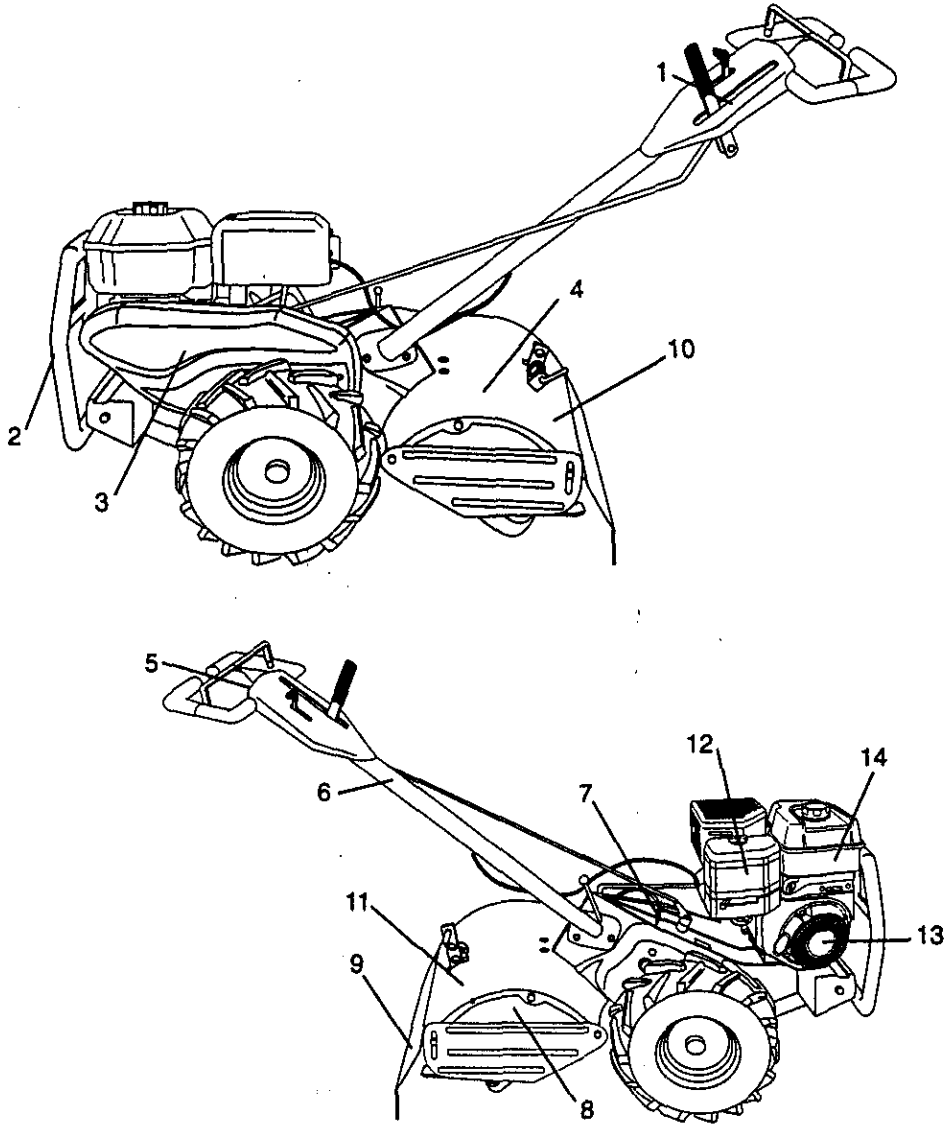

KEY PART

KEY NO.	PART NO.	DESCRIPTION
1	166213	Decal, Logo
2	145023	Decal, Logo
3	166134	Decal, Logo
4	166133	Decal, Description
5	137538	Decal, Caution, Drive Control
6	120431X	Decal, Hand Placement
7	102180X	Decal, Shift Indicator
8	157984	Decal, Tine, Shield, Counter Rotating Tines
9	120075X	Decal, Warning, Rotating Tines
10	163094	Decal, Tine Depth Stake
11	162215	Decal, Tine, Shield, Warning Dom
12	166138	Decal, Engine
13	166854	Decal, Engine 6HP REF
14	167155	Decal, Craftsman IC
--	166007	Manual, Owner's (Eng/Span)

TILLER - - MODEL NUMBER 917.293310
ENGINE, BRIGGS & STRATTON - - MODEL NUMBER 121432-0124-E1

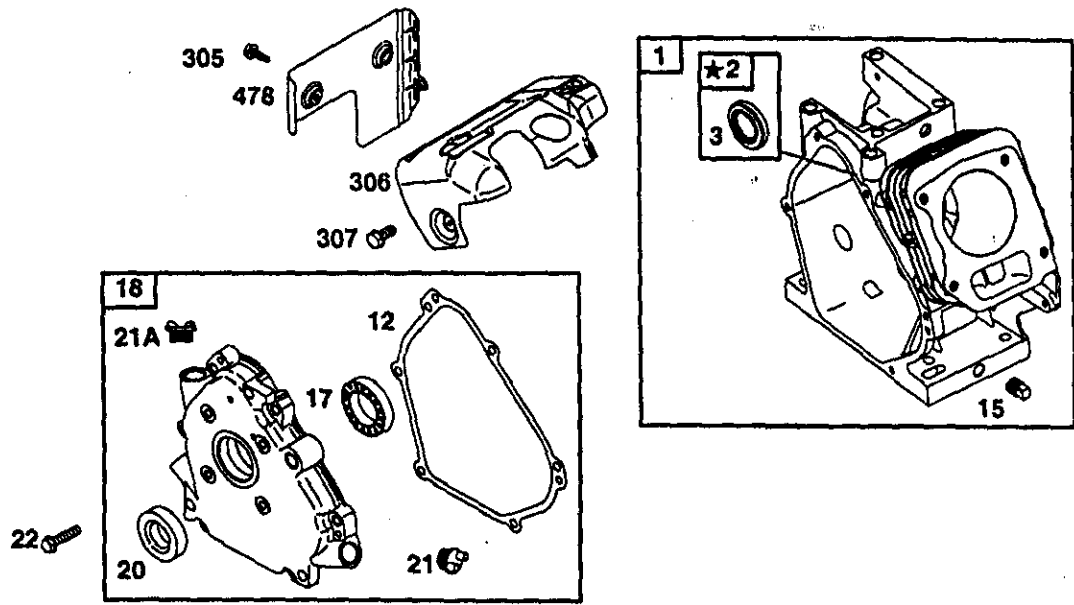

1019 LABEL KIT
1058 OWNER'S MANUAL

★ **REQUIRES SPECIAL TOOLS TO INSTALL. SEE REPAIR INSTRUCTION MANUAL.**

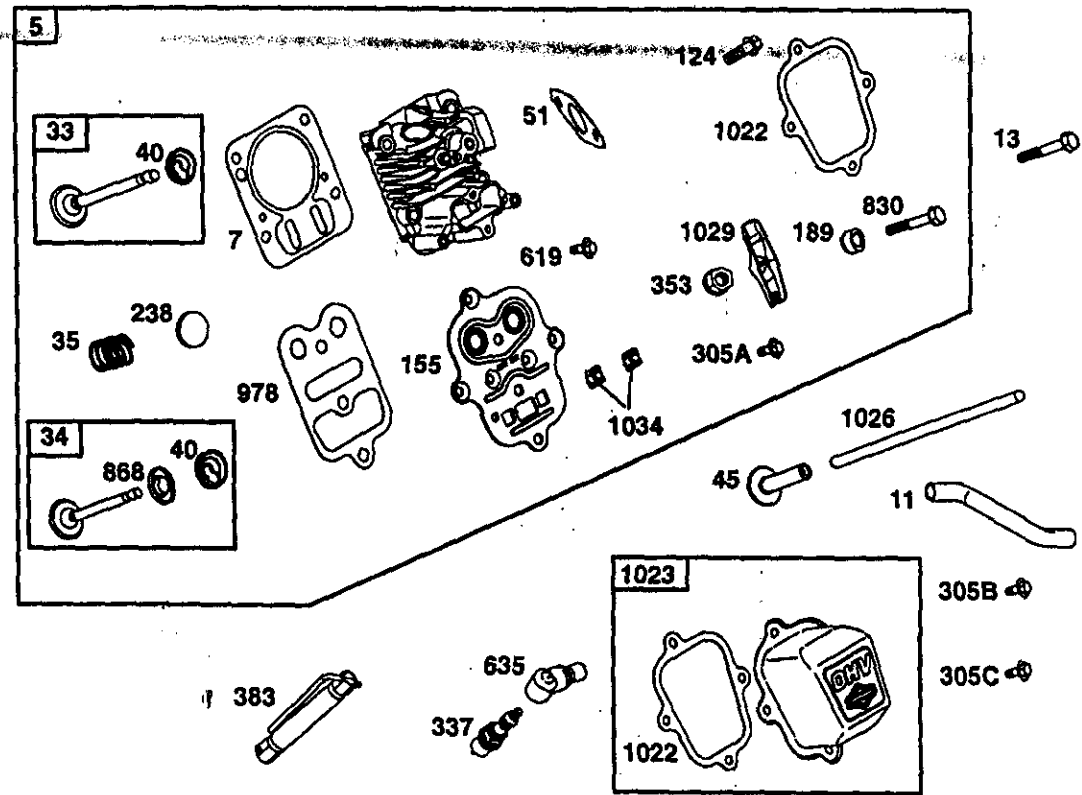

TILLER - - MODEL NUMBER 917.293310
ENGINE, BRIGGS & STRATTON - - MODEL NUMBER 121432-0124-E1

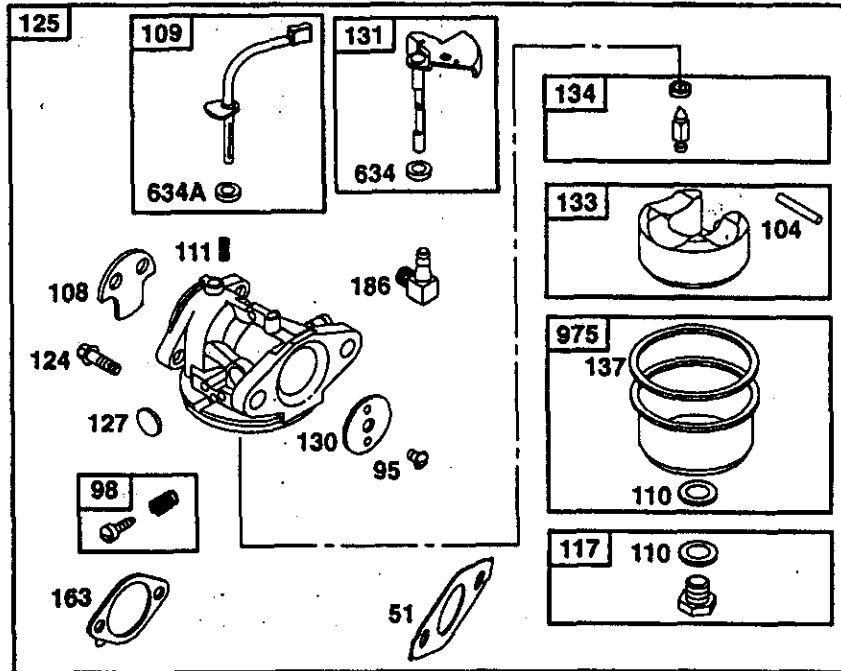
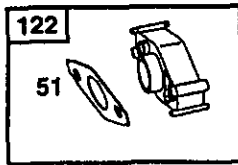
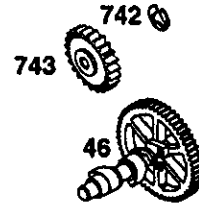
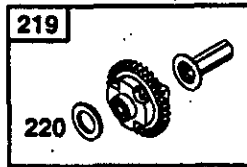
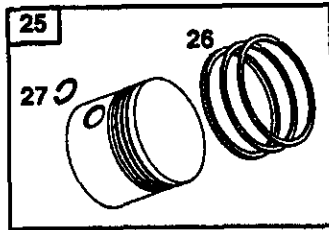
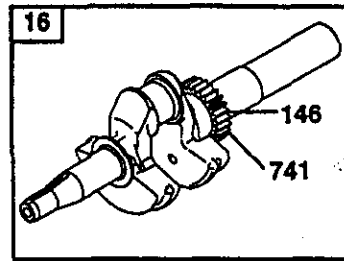
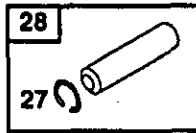
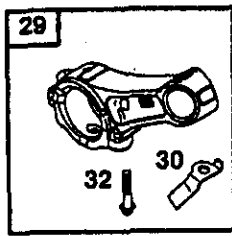

TILLER - - MODEL NUMBER 917.293310
 ENGINE, BRIGGS & STRATTON - - MODEL NUMBER 121432-0124-E1

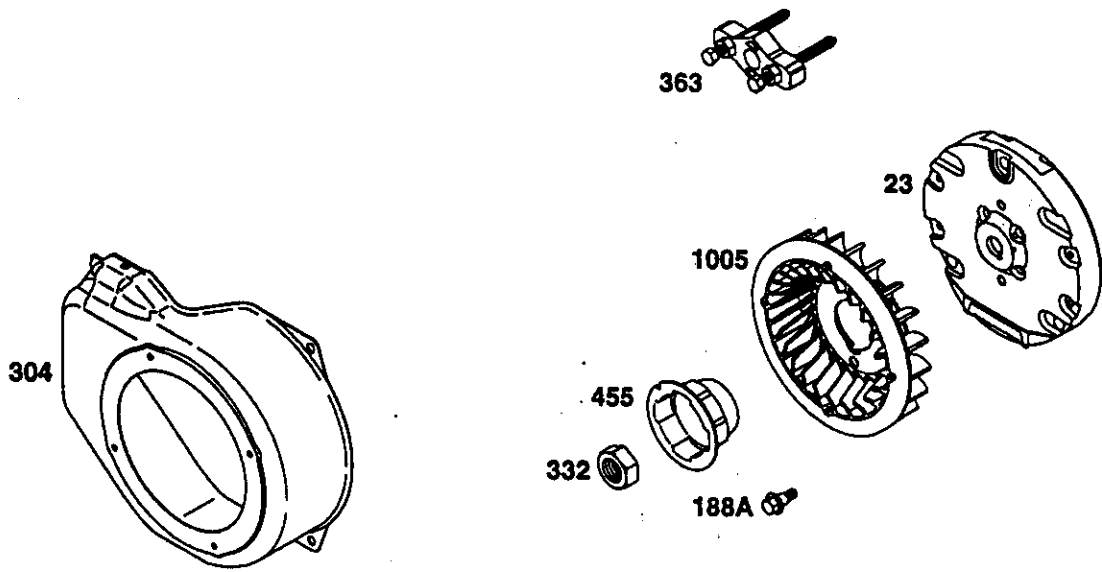

305A Ⓢ

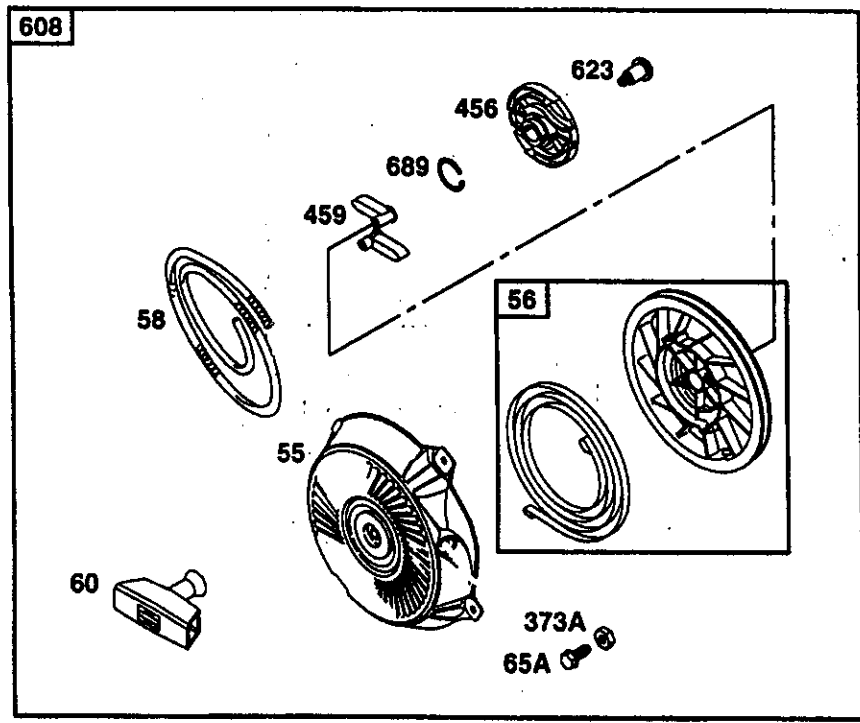

TILLER -- MODEL NUMBER 917.293310
 ENGINE, BRIGGS & STRATTON -- MODEL NUMBER 121432-0124-E1

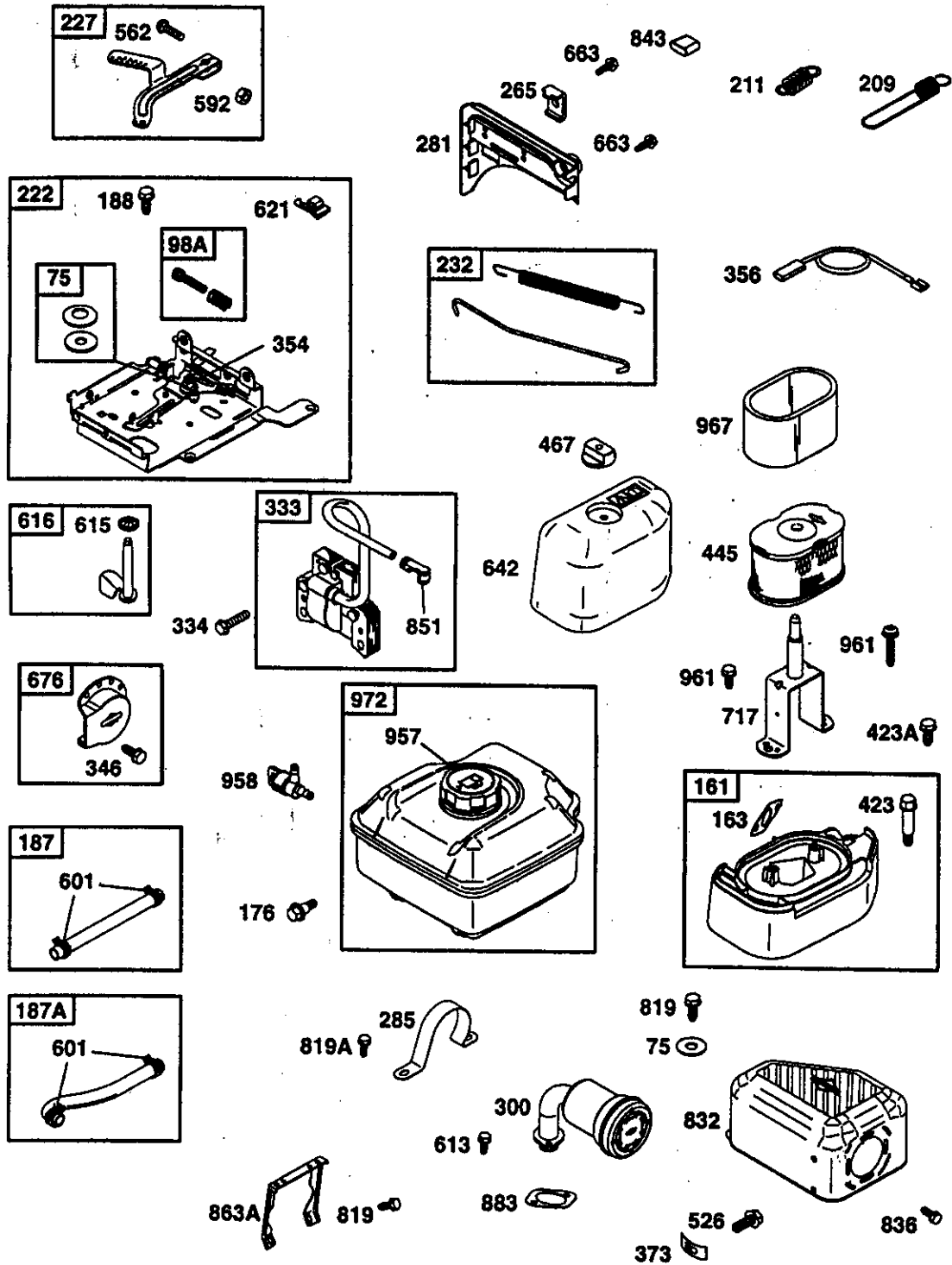

TILLER - - MODEL NUMBER 917.293310
ENGINE, BRIGGS & STRATTON - - MODEL NUMBER 121432-0124-E1

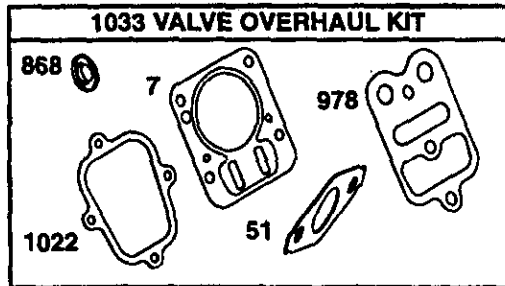
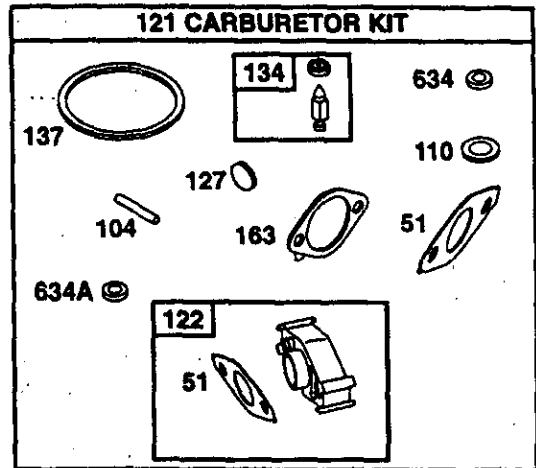
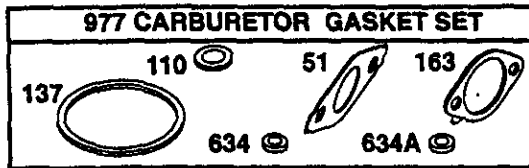
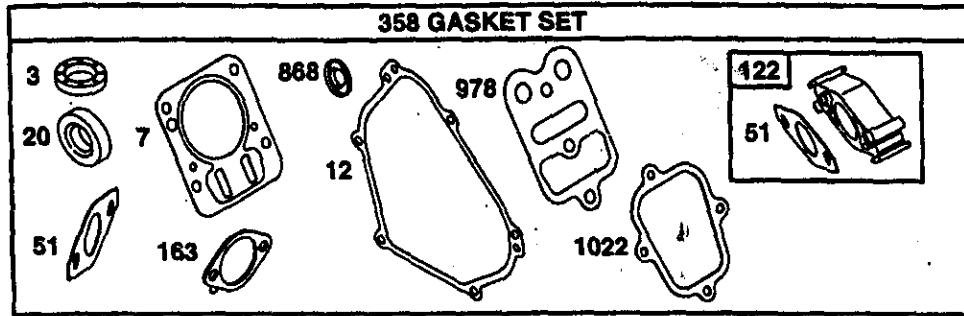

TILLER -- MODEL NUMBER 917.293310

ENGINE, BRIGGS & STRATTON -- MODEL NUMBER 121432-0124-E1

KEY NO.	PART NO.	DESCRIPTION	KEY NO.	PART NO.	DESCRIPTION
1	690045	Cylinder Assembly	109	693628	Choke Shaft
2	399269	Bushing, Cylinder	110	— —	◆● Washer, Seal (Sold In Kit Only)
3	299819	★ Seal, Oil	111	262715	Spring Friction (Choke)
5	693643	Head, Cylinder	117	690048	Jet, Main (Standard)
7	273489	Δ★ Gasket, Cylinder Head	121	690032	Carburetor kit
11	693647	Tube, Breather	122	690043	★ Spacer, Carburetor
12	692549	★ Gasket, Crankcase	124	692568	Screw, Carburetor
13	95049	Screw, Cylinder Head	125	693518	Carburetor
15	94916	Plug, Oil Drain	127	— —	● Plug, Welch (Sold in Kit Only)
16	693403	Crankshaft	130	223470	Valve, Throttle
17	498185	Bearing, Ball	131	690024	Shaft Throttle
18	693204	Cover-Crankcase	133	398187	Float Carburetor
20	692550	★ Seal, Oil	134	398188	● Valve, Needle
21	281658	Cap, Oil Fill	137	— —	◆● Gasket Float Bowl (Sold In Kit Only)
21A	693463	Cap, Oil Fill			
22	692551	Screw, Crankcase Cover	146	94388	Key, Timing
23	692987	Flywheel	155	225430	Plate, Cylinder Head
24	222698	Key, Flywheel	161	693459	Base, Air Cleaner
25	499627	Piston Assembly (Std.)	163	272948	◆●★ Gasket, Air Cleaner
	692788	Piston Assembly, .010" O/S	176	94905	Screw, Shoulder
	692789	Piston Assembly, .020" O/S	186	493496	Connector, Hose
	692790	Piston Assembly, .030" O/S	187	298049	Line, Fuel (Cut to Required Length)
26	499631	Ring Set, (Std.)	187A	692601	Line, Fuel (Molded)
	692785	Ring Set, .010" O/S	188	94644	Screw, Control Bracket
	692786	Ring Set, .020" O/S	188A	692590	Screw, Shoulder
	692787	Ring Set, .030" O/S	189	263108	Ball, Rocker Arm
27	263190	Lock, Piston Pin	209	693710	Spring, Governor
28	499423	Pin, Piston	211	693710	Spring, Governor Idle
29	690124	Rod, Connecting	219	693578	Gear Governor
30	225279	Dipper, Connecting Rod	220	221551	Washer -Thrust
32	94699	Screw, Connecting Rod	222	693405	Bracket, Control
33	499642	Valve, Exhaust	227	499506	Lever, Governor
34	499641	Valve, Intake	232	693408	Spring, Link, Mechanical Governor
35	263149	Spring, Valve			
40	93312	Retainer, Valve			
45	262679	Tappet, Valve			
46	693404	Camshaft			
51	692555 ★●◆Δ	Gasket, Intake			
55	497442	Housing, Rewind Starter			
56	498144	Pulley, Starter			
58	280399	Rope, Starter			
60	281101	Grip, Starter Rope			
65	692608	Screw, Hex.			
65A	94904	Screw, Hex.			
75	495659	Washer, Set			
95	94098	Screw, Choke/Slotted			
98	398185	Screw, Idle Speed			
98A	493280	Screws Idle Speed			
104	231371	● Pin, Float Hinge			
108	223471	Valve, Choke			

RPM Settings Low: 1650-1850; High: 3500-3700.

★ Included in Gasket Set, Ref Number 358.

● Included in Carburetor Kit, Ref Number 121.

◆ Included in Carburetor Gasket Set, Ref Number 977.

Δ Included in Valve Overhaul Kit, Ref Number 1033.

NOTE: All component dimensions are given in U.S. inches. 1 inch = 25.4 mm

TILLER - - MODEL NUMBER 917.293310

ENGINE, BRIGGS & STRATTON - - MODEL NUMBER 121432-0124-E1

KEY NO.	PART NO.	DESCRIPTION	KEY NO.	PART NO.	DESCRIPTION
238	263131	Cap, Valve	743	692566	Gear, Idler
265	221535	Clamp, Casing	819	692598	Screw, Muffler Strap
281	693407	Panel, Control	819A	94914	Screw
285	692595	Strap, Muffler	830	94993	Screw-Hex.
300	693593	Muffler, Exhaust	832	693583	Guard, Muffler
304	693621	Housing, Blower	836	94896	Screw, Muffler Guard
305	692577	Screw, Panel	836A	692596	Bracket, Muffler
305A	690960	Screw, Blower Housing	851	493880	Terminal, Cable
305B	692557	Screw, Rocker Cover 3/8" Long	863A	692596	Bracket, Muffler
305C	94786	Screw, Rocker Cover 7/16" Long	868	498592	Δ★ Seal, Valve
306	693610	Shield, Cylinder	883	272309	Gasket, Exhaust
307	94515	Screw, Cylinder Shield	957	493988	Cap, Fuel Tank
332	94877	Nut, Flywheel	958	692586	Valve, Shutoff
333	692605	Armature, Magneto	961	963598	Screw, Air Cleaner Bracket
334	94731	Screw, Armature Magneto	967	273356	Filter, Air Pre-Cleaner
337	491055	Spark Plug	972	692587	Tank, Fuel
346	94896	Screw	975	493640	Bowl, Float
353	95137	Nut-Hex	977	690033	Gasket Set, Carburetor
354	692575	Nut, Lock	978	273346	Δ★ Gasket, Plate
356	398808	Wire, Stop	1005	692592	Fan, Flywheel
358	690031	Gasket Set	1019	690035	Label Kit
363	19069	Flywheel Puller	1022	273241	Δ★ Gasket, Rocker Cover
373	692582	Nut, Clip	1023	499924	Cover, Rocker
373A	94907	Nut, Hex.	1026	693517	Rod, Push
383	19374	Wrench, Spark Plug	1029	225246	Arm, Rocker
423	94655	Screw, Air Cleaner Base	1033	690034	Kit, Valve Overhaul
423A	94929	Screw, Air Cleaner Base	1034	281621	Guide, Push Rod
445	498596	Filter A/C Cartridge	1058	273700	Owner's Manual
455	225457	Cup, Flywheel	---	---	Replacement Engine 121432-0036-E2
456	281503	Retainer, Spring	---	---	Replacement S/B not available at this time
459	281505	Pawl, Ratchet			
467	493903	Knob, Air Cleaner			
478	693709	Panel			
526	94974	Screw			
562	94852	Bolt, Governor Lever			
592	231082	Nut, Governor Lever			
601	93053	Clamp, Hose			
608	497830	Starter, Rewind			
613	94706	Screw, Muffler Mounting			
615	94672	Retainer, Governor			
616	692547	Crank, Governor			
619	94744	Screw, Cyl. Head Plate			
621	396847	Switch, Stop			
623	94943	Screw, Shoulder			
634	---	◆● Washer Sold in Kit Only)			
634A	---	◆● Washer (Sold In Kit Only)			
635	805529	Boot, Spark Plug			
642	693460	Cover, Air Cleaner			
663	692577	Screw, Casing Clamp			
676	393757	Deflector, Muffler			
689	263073	Spring, Friction			
717	693462	Air Cleaner Bracket			
741	263157	Gear, Timing			
742	692564	Ring, Retaining			

RPM Settings Low: 1650-1850; High: 3500-3700.

★ Included in Gasket Set, Ref Number 358.

● Included in Carburetor Kit, Ref Number 121.

◆ Included in Carburetor Gasket Set, Ref Number 977.

Δ Included in Valve Overhaul Kit, Ref Number 1033.

NOTE: All component dimensions are given in U.S. inches. 1 inch = 25.4 mm

For the repair or replacement parts you need
delivered directly to your home
Call 7 am - 7 pm, 7 days a week

1-800-366-PART

(1-800-366-7278)

Para ordenar piezas con entrega a
domicilio - 1-800-659-7084

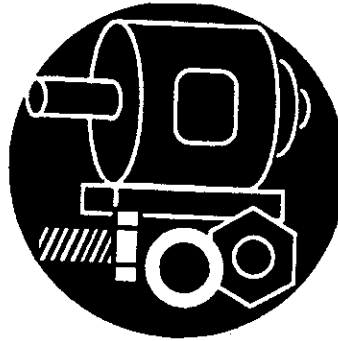

For in-house major brand repair service
Call 24 hours a day, 7 days a week

1-800-4-REPAIR

(1-800-473-7274)

Para pedir servicio de reparación a
domicilio - 1-800-676-5811



For the location of a Sears Parts and
Repair Center in your area

Call 24 hours a day, 7 days a week

1-800-488-1222



For information on purchasing a Sears
Maintenance Agreement or to inquire
about an existing Agreement

Call 9 am - 5 pm, Monday-Saturday

1-800-827-6655



When requesting service or ordering
parts, always provide the following
information:

- Product Type
- Part Number
- Model Number
- Part Description

SEARS
REPAIR SERVICES

America's Repair Specialists